



↓ تم تحميل ملف المادة من مكتبة طلابنا
زورونا على الموقع

www.tlabna.net

مكتبه طلابنا تقدم لكم كل ما يحتاج المعلم والمعلمه والطلبة , الطبعات الجديده للكتب والحلول ونماذج الاختبارات والتحاثير وشروحات الدروس بصيغة الورد والبي دي اف وكذلك عروض البوربوينت.

Now I Know My COLORS, SHAPES & PATTERNS

Learning Mats

50+ Double-Sided Activity Sheets That Help Children
Learn Key Early Concepts

Color Patterns: ABB

37 ☆ Name: Arienne

Make a color pattern in each row. Use the color key.

Color Key
☀ = yellow 🐦 = blue 🍃 = green

1. 🍃 ☀ ☀ 🍃 ☀ ☀

2. ☀ 🐦 🐦 ☀ 🐦 🐦

3. 🐦 🍃 🍃 🐦 🍃 🍃



Shapes: Circle

44 ☆ Name: Kyle

Trace the word. 🖍

😊 circle
😊 circle
😊 circle

Trace the shape.

Draw a ○ ball.

Write circle.

circle



**Build Skills
in Minutes
a Day!**

 SCHOLASTIC

Now I Know My

COLORS, SHAPES & PATTERNS

Learning Mats

*50+ Double-Sided Activity Sheets That Help Children
Learn Key Early Concepts*

Lucia Kemp Henry

New York • Toronto • London • Auckland • Sydney
Mexico City • New Delhi • Hong Kong • Buenos Aires

**Teaching
Resources**

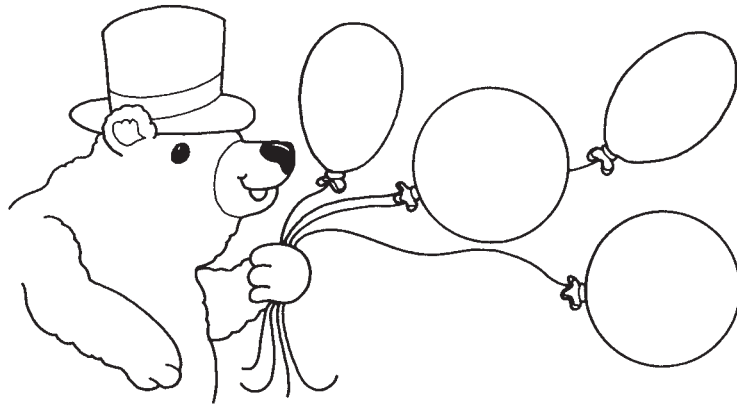

Scholastic Inc. grants teachers permission to photocopy the reproducible pages in this book for classroom use. No other part of this publication may be reproduced in whole or in part, or stored in a retrieval system, or transmitted in any form or by any means, electronic, photocopying, recording, or otherwise, without written permission of the publisher.

For information regarding permission, write to Scholastic Inc., 557 Broadway, New York, NY 10012-3999.

Edited by Immacula A. Rhodes
Cover design by Scott Davis
Interior illustrations by Lucia Kemp Henry
Interior design by Holly Grundon

ISBN: 978-0-545-39697-4

Text and illustrations © 2012 by Scholastic Inc.
All rights reserved.
Published by Scholastic Inc.
Printed in the U.S.A.

1 2 3 4 5 6 7 8 9 10 40 19 18 17 16 15 14 13 12

Contents

About This Book	5
Meeting the Standards	8

Learning Mats

Colors

	Mat	Skill
page 9	1–2.....	Red (<i>read and write red; identify and draw red items</i>)
page 11	3–4.....	Yellow (<i>read and write yellow; identify and draw yellow items</i>)
page 13	5–6.....	Blue (<i>read and write blue; identify and draw blue items</i>)
page 15	7–8.....	Green (<i>read and write green; identify and draw green items</i>)
page 17	9–10.....	Review (<i>red, yellow, blue, and green</i>)
page 19	11–12.....	Orange (<i>read and write orange; identify and draw orange items</i>)
page 21	13–14.....	Purple (<i>read and write purple; identify and draw purple items</i>)
page 23	15–16.....	Black (<i>read and write black; identify and draw black items</i>)
page 25	17–18.....	Brown (<i>read and write brown; identify and draw brown items</i>)
page 27	19–20.....	Review (<i>orange, purple, black, and brown</i>)
page 29	21–22.....	Review (<i>red, yellow, blue, green, orange, purple, black, and brown</i>)
page 31	23–24.....	Color Patterns: AB
page 33	25–26.....	Color Patterns: AB
page 35	27–28.....	Color Patterns: AAB
page 37	29–30.....	Color Patterns: ABB
page 39	31–32.....	Color Patterns: AABB
page 41	33–34.....	Color Patterns: ABC

Shapes

	Mat	Skill
page 43	35–36.....	Circle (<i>draw and identify circles; read and write circle</i>)
page 45	37–38.....	Square (<i>draw and identify squares; read and write square</i>)
page 47	39–40.....	Triangle (<i>draw and identify triangles; read and write triangle</i>)
page 49	41–42.....	Rectangle (<i>draw and identify rectangles; read and write rectangle</i>)
page 51	43–44.....	Review (<i>circle, square, triangle, and rectangle</i>)

Learning Mats (continued)

	Mat	Skill
page 53	45–46.	Oval (<i>draw and identify ovals; read and write oval</i>)
page 55	47–48.	Octagon (<i>draw and identify octagons; read and write octagon</i>)
page 57	49–50.	Star (<i>draw and identify stars; read and write star</i>)
page 59	51–52.	Diamond (<i>draw and identify diamonds; read and write diamond</i>)
page 61	53–54.	Review (<i>oval, octagon, star, and diamond</i>)
page 63	55–56.	Shape Patterns: AB
page 65	57–58.	Shape Patterns: AB
page 67	59–60.	Shape patterns: AAB
page 69	61–62.	Shape Patterns: ABB
page 71	63–64.	Shape Patterns AABB
page 73	65–66.	Shape Patterns: ABC
page 75	67–68.	Attributes: Color & Shape
page 77	69–70.	Attributes: Color & Size
page 79	71–72.	Attributes: Shape & Size

Patterns

	Mat	Skill
page 81	73–74.	Pictures (<i>mixed patterns</i>)
page 83	75–76.	Pictures (<i>mixed patterns</i>)
page 85	77–78.	Letters (<i>mixed patterns; uppercase letters</i>)
page 87	79–80.	Letters (<i>mixed patterns; uppercase letters</i>)
page 89	81–82.	Letters (<i>mixed patterns; lowercase letters</i>)
page 91	83–84.	Letters (<i>mixed patterns; lowercase letters</i>)
page 93	85–86.	Letters (<i>mixed patterns; mixed letters</i>)
page 95	87–88.	Numbers (<i>mixed patterns; numbers 1–5</i>)
page 97	89–90.	Numbers (<i>mixed patterns; numbers 1–9</i>)
page 99	91–92.	Review (<i>mixed patterns; letters and numbers</i>)
page 101	93–94.	Review (<i>mixed patterns; pictures and shapes</i>)
page 103	95–96.	Identifying Patterns (AB)
page 105	97–98.	Identifying Patterns (AAB)
page 107	99–100.	Identifying Patterns (ABB)
page 109	101–102.	Identifying Patterns (AABB)
page 111	103–104.	Identifying Patterns (ABC)

About This Book

Welcome to *Now I Know My Colors, Shapes & Patterns Learning Mats*! The 104 double-sided mats in this book provide engaging activities designed to help children master essential early skills and concepts. In addition, the systematic format reinforces literacy and fine-motor skills while enabling children to work independently.

The interactive, reproducible mats feature appealing art and simple, predictable text that targets specific colors, shapes, and patterns. Activities include identifying eight different colors and shapes; reading and writing color and shape words; tracing, drawing, and matching shapes; and recognizing and creating basic patterns with colors, shapes, and symbols. The drawing and writing exercises help develop and strengthen fine-motor skills as well as reinforce shape, letter, and word recognition. And, as children read and follow directions to complete each mat, they build critical vocabulary and comprehension skills. To help meet the learning needs of your students, refer to page 8 to see how activities in this book connect to the Common Core State Standards for Reading (Foundational Skills), Language, and Mathematics, as well as to the standards recommended by the National Council of Teachers of Mathematics (NCTM).

Preparing and using the learning mats is quick and easy! Simply make double-sided copies to use for instruction with the whole class, small groups, student pairs, or individuals. The mats are also ideal for independent work, centers, and homework. You'll find that daily practice with these activities helps build and reinforce knowledge of basic concepts and boosts early literacy skills. Best of all, children will experience the joy of learning as they develop skills that help them grow into more confident, fluent readers.

What's Inside

The learning mats in this resource are divided into three sections: Colors (mats 1–34), Shapes (mats 35–72), and Patterns (mats 73–104). Activities on each mat target a specific color, shape, or pattern. Review mats are also included to provide extra practice for each concept. Although a separate section is dedicated to patterns, activities that involve patterning with colors and shapes are found in those respective sections. Mats in the patterns section give children practice in recognizing, extending, and creating patterns with pictures and symbols (such as letters and numbers).

The mats are ready to use. Simply decide on the skill or topic you want to teach, locate the corresponding mats in the book, and make a double-sided copy of those mats. The only materials kids need for the activities are crayons or colored pencils. To use, children read and follow the directions to complete each activity. You'll find several activity formats throughout the book, as described on pages 6–7.

Colors

- ❖ **Trace and Write:** Children trace the target color word and then write the word on their own without guides. This exercise reinforces letter formation, word recognition, and spelling.
- ❖ **Identify Object Colors:** This activity lets children identify and color objects that are commonly found—in real life—in a specific color.
- ❖ **Identify the Word:** Children use visual discrimination skills to identify the target word from similarly spelled or shaped words.
- ❖ **Drawing:** This activity helps develop fine-motor skills while reinforcing the targeted color concept.
- ❖ **Fill-in-the-Blank:** Children use context by writing the target word in a sentence that connects to the art they drew in the previous activity.
- ❖ **Review:** Color-coded pictures help reinforce color word recognition and fine-motor skills. A writing activity offers additional practice in recognizing, spelling, and writing color words.
- ❖ **Color Patterns:** Children use a color key to create AB, AAB, ABB, AABB, and ABC patterns.



Shapes

- ❖ **Trace the Shape:** To develop shape recognition and fine-motor skills, children trace the target shape in two activities on these mats.
- ❖ **Identify the Shape:** Children identify the target shape from a variety of shapes and then color the appropriate ones.
- ❖ **Trace and Write:** In this activity, children trace the target shape word and then write the word on their own.
- ❖ **Drawing:** To target shape concepts and fine-motor skills, children draw a picture using a specific shape.
- ❖ **Review:** These color-coded pictures reinforce shape word recognition and fine-motor skills. A writing activity gives children more practice in recognizing, spelling, and writing shape words.
- ❖ **Shape Patterns:** Children draw shapes to complete AB, AAB, ABB, AABB, and ABC patterns.
- ❖ **Identify Attributes:** Activities on these mats help sharpen reasoning skills. Children color the shapes and then identify which shape matches the specific attributes stated in the directions.

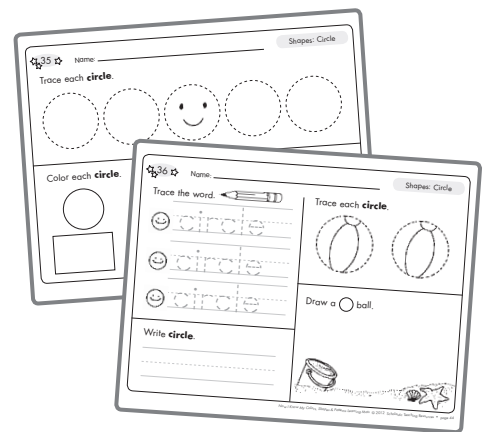

Patterns

- ❖ **Complete the Patterns:** Children complete patterns by drawing pictures or filling in the missing letter or numbers. Each mat features a variety of patterns.
- ❖ **Review:** In these activities, children demonstrate understanding of patterns by identifying the item or shape that comes next in a pattern, as well as creating their own patterns.
- ❖ **Identify Patterns:** Children identify, label, and create their own AB, AAB, ABB, AABB, and ABC patterns.

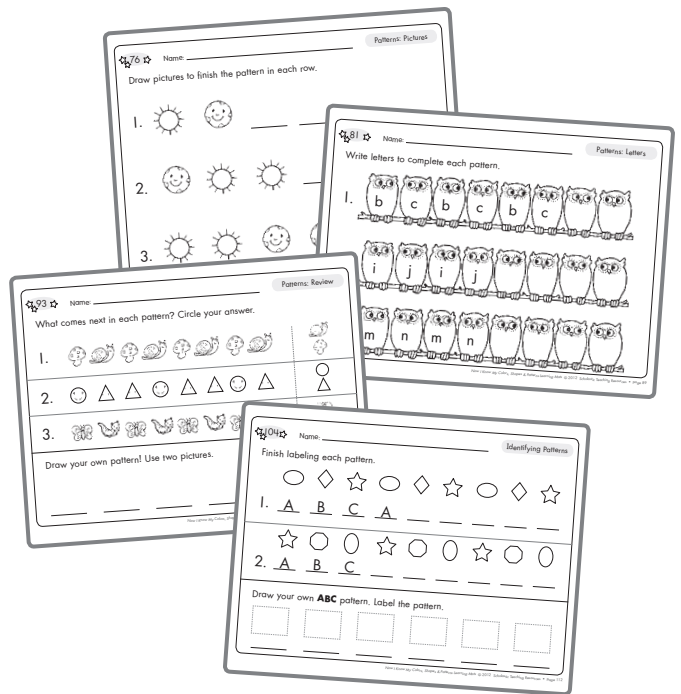

Helpful Tips

The following suggestions will help you and your students get the most out of the learning mats:

- Complete each mat in advance to become familiar with the directions, art, and response for each activity. If desired, laminate your completed copy to use as an answer key. (Or slip the mat into a clear, plastic page protector.) You might bind all of your answer keys into a notebook to keep on hand for children to check their work.
- Use the mats to introduce new concepts, track children's progress in mastering essential skills, and review concepts already covered.
- Prepare the mats for repeated use in learning centers. Simply laminate the double-sided mats and put them in a center along with wipe-off color crayons and paper towels (to use as erasers).
- Compile sets of the learning mats into booklets for children to complete in class or at home. For example, you might staple copies of mats 1–6 between two sheets of construction paper and title the booklet, "My Red, Yellow, and Blue Book."
- The mats are also perfect for instant homework assignments. Send the pages home with children to complete. This is an easy way to reinforce skills covered in class, as well as to keep families informed about what their children are learning, what they've mastered, and where they might need some extra guidance.

Meeting the Standards

Connections to the Common Core State Standards

The Common Core State Standards Initiative (CCSSI) has outlined learning expectations in English/Language Arts and Mathematics for students at different grade levels. The activities in this book align with the following standards for students in grades K–1. For more information, visit the CCSSI Web site at www.corestandards.org.

Reading Standards: Foundational Skills

Print Concepts

- RF.K.1, RF.1.1. Demonstrate understanding of the organization and basic features of print.
- RF.K.1a. Recognize and name all upper- and lowercase letters of the alphabet.

Phonological Awareness

- RF.K.2, RF.1.2. Demonstrate understanding of spoken words, syllables, and sounds (phonemes).

Phonics and Word Recognition

- RF.K.3, RF.1.3. Know and apply grade-level phonics and word analysis skills in decoding words.

Fluency

- RF.K.4, RF.1.4. Read with sufficient accuracy and fluency to support comprehension.
- RF.1.4a. Read grade-level text with purpose and understanding.
- RF.1.4b. Read grade-level text orally with accuracy, appropriate rate, and expression.
- RF.1.4c. Use context to confirm or self-correct word recognition and understanding, rereading as necessary.

Language

Conventions of Standard English

- L.K.1, L.1.1. Demonstrate command of the conventions of standard English grammar and usage when writing or speaking.
- L.K.1a, L.1.1a. Print upper- and lowercase letters.
- L.K.2, L.1.2. Demonstrate command of the conventions of standard English capitalization, punctuation, and spelling when writing.

Mathematics

Counting & Cardinality

- K.CC.3. Write numbers from 0 to 20.

Geometry

- K.G.2. Correctly name shapes regardless of their orientations or overall size.
- K.G.4. Analyze and compare two-dimensional shapes, in different sizes and orientations.
- 1.G.1 Distinguish between defining attributes (e.g., triangles are closed and three-sided) versus non-defining attributes (e.g., color, orientation, overall size).

Connections to the NCTM Math Standards

The activities also help support you in meeting the following PreK–1 standards—including process standards, such as problem solving, reasoning and proof, and communication—recommended by the National Council of Teachers of Mathematics (NCTM):

Geometry

Analyze characteristics and properties of two-dimensional geometric shapes

- Recognize, name, compare, and sort shapes
- Describe attributes and parts of shapes

Use visualization, spatial reasoning, and geometric modeling to solve problems

- Recognize and represent shapes from different perspectives

Algebra

Understand patterns, relations, and functions

- Recognize, describe, and extend patterns
- Analyze how repeating patterns are generated

Source: National Council of Teachers of Mathematics. (2000). *Principles and Standards for School Mathematics*. Reston, VA: NCTM. www.nctm.org



Name: _____

Color: Red



Trace the word.



red



red



red

Which things are **red** in real life?
Color them.

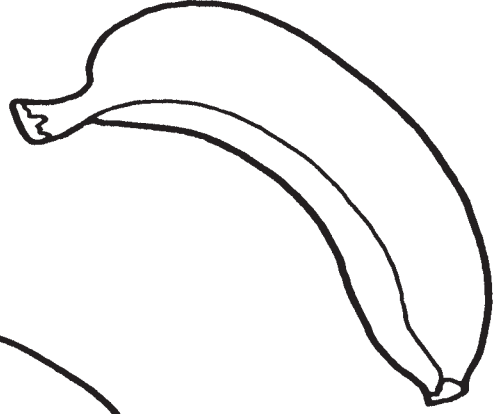
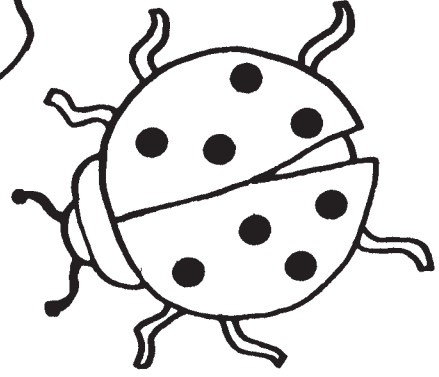
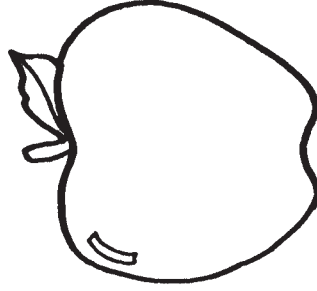
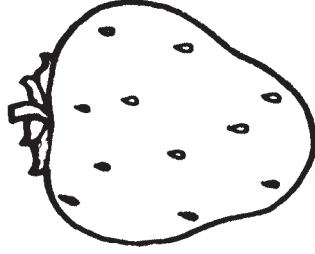
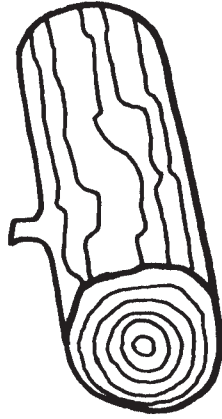

Write **red**.



Name: _____

Color: Red

Circle each **red**.

red

run

rot

bar

red

red

Draw a strawberry. Color each strawberry **red**.

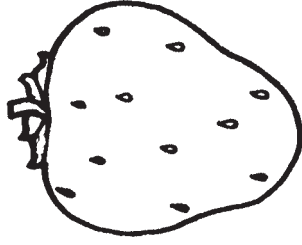
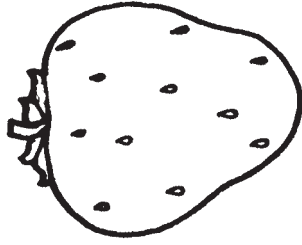
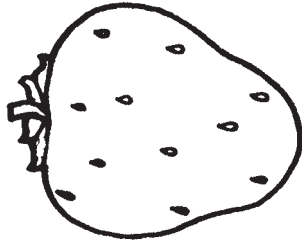

Write **red**.

The strawberries are _____.

3

Color: Yellow

Name: _____



Trace the word.



yellow



yellow



yellow

Write **yellow**.

Blank lines for writing the word 'yellow'.

Which things are **yellow** in real life? Color them.

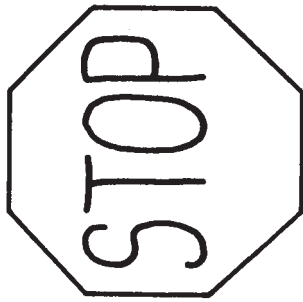
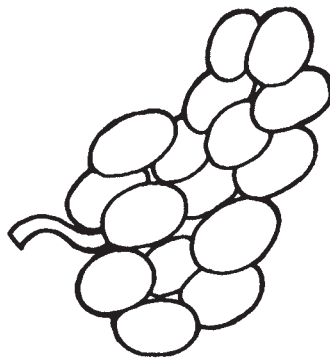
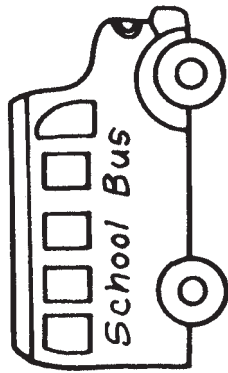
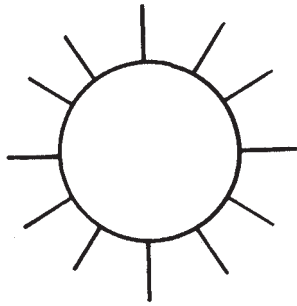



Name: _____

Color: Yellow

Circle each **yellow**.

wall

yellow

your

yellow

anyhow

yellow

Draw a banana. Color each banana **yellow**.



Write **yellow**.

I want to eat a _____

_____ banana.

Trace the word.



Three sets of handwriting practice lines. Each set consists of a solid top line, a dashed middle line, and a solid bottom line. The word "blue" is written in dashed letters across the middle line of each set. To the left of each set is a ribbon award with the number "1st" written on it.

Write blue.

Three sets of handwriting practice lines for independent writing. Each set consists of a solid top line, a dashed middle line, and a solid bottom line.

Which things are **blue** in real life?
Color them.

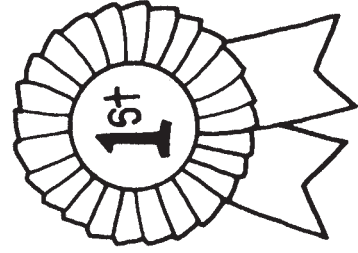
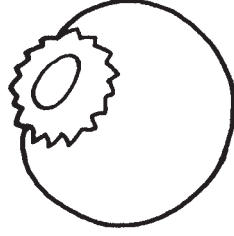

Name: _____

Color: Blue

Circle each **blue**.

bulb

ball

blue

blue

blue

bold

Draw a bird. Color each bird **blue**.



Write **blue**.

Watch the _____ birds fly.

Name: _____

Color: Green

Trace the word.



green



green



green

Write **green**.

Blank lines for writing the word 'green'.

Which things are **green** in real life?
Color them.

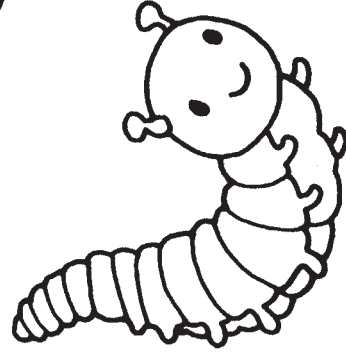
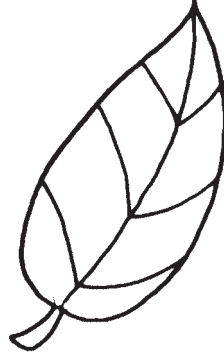
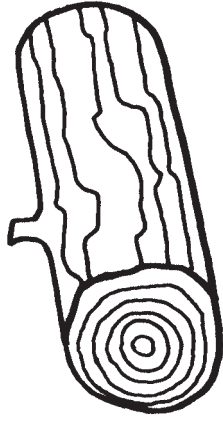
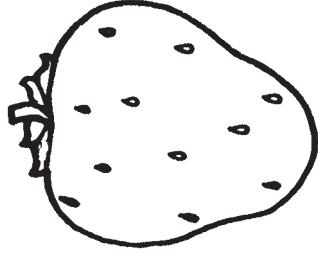

Name: _____

Color: Green

Circle each **green**.

great

green

green

green

seen

game

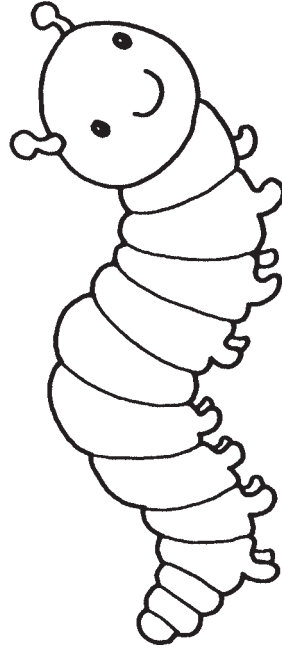
Draw a caterpillar. Color each caterpillar **green**.Write **green**.

The caterpillars are _____.

Color the picture. Use the Color Key.

Color Key



= red



= yellow



= green



= blue

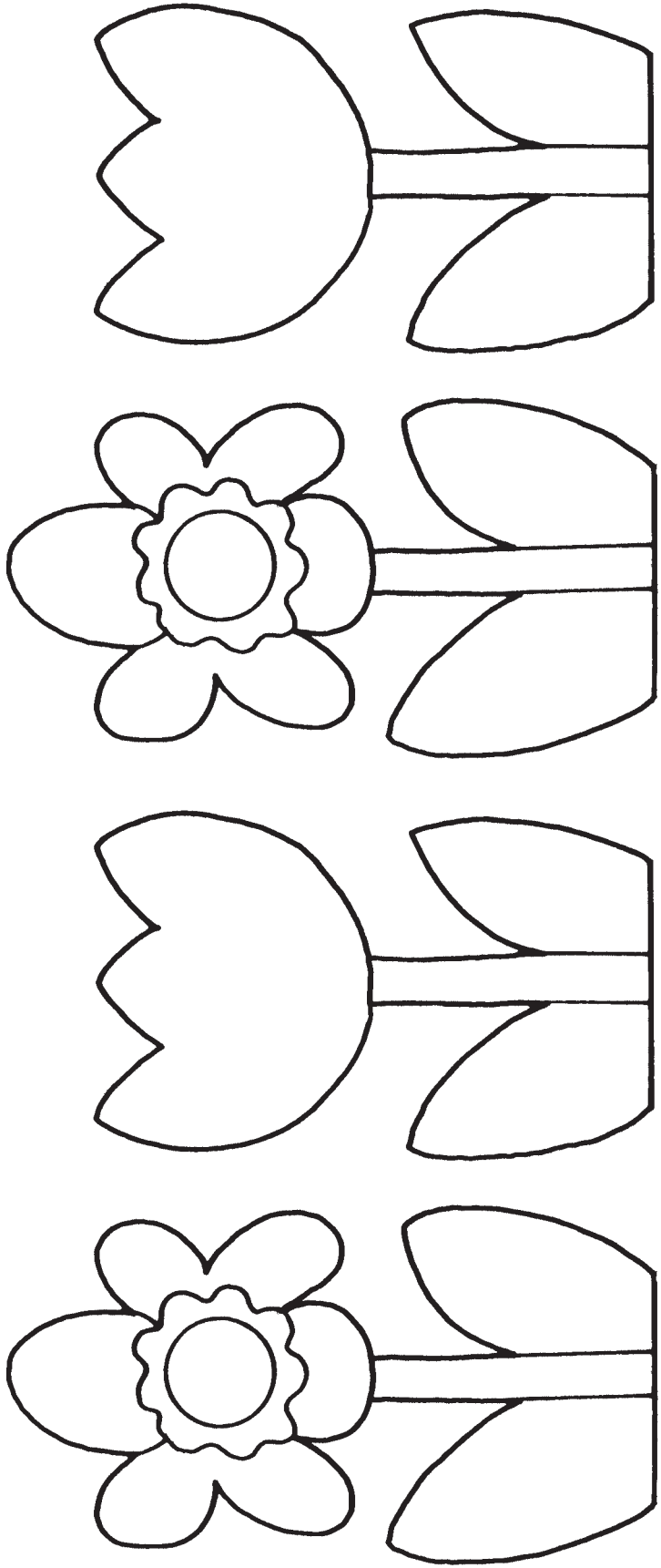

Name: _____

Colors: Review

Write the color for each picture.
Use the words in the box.
Then color the pictures.

blue green yellow red

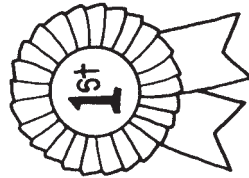

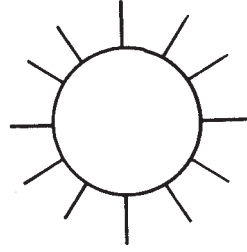

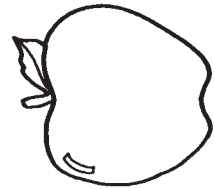

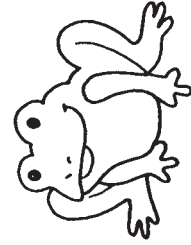



Name: _____

Color: Orange



Trace the word.

orange



orange



orange



Which things are **orange** in real life? Color them.

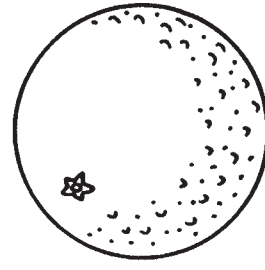
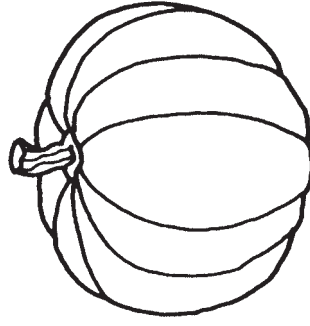
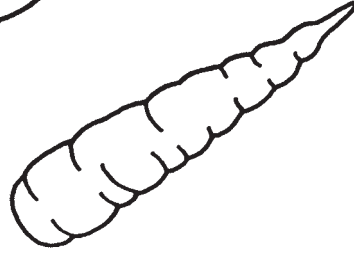
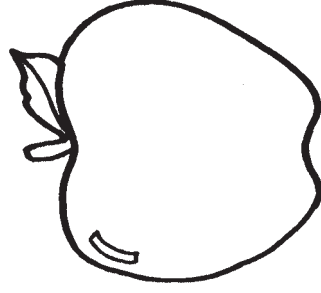

Write **orange**.

Name: _____

Color: Orange

Circle each **orange**.

orange

grain

orange

grand

orange

cover

Draw a pumpkin. Color each pumpkin **orange**.

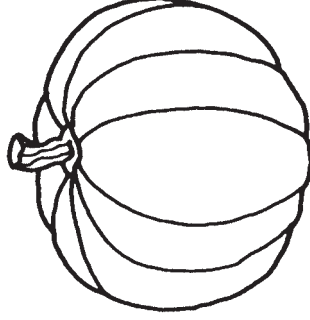
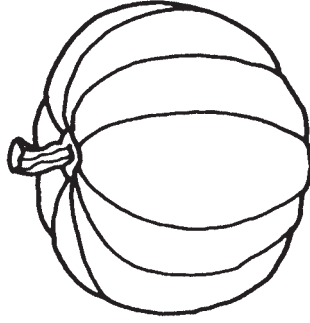
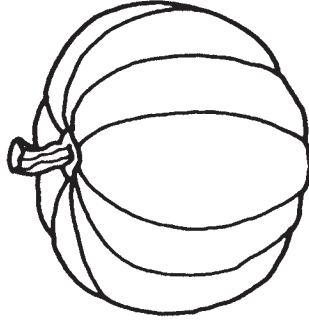

Write **orange**.

Look at the big _____

_____ pumpkins.

Name: _____

Color: Purple

Trace the word.



purple



purple



purple

Write purple.

Blank handwriting lines for writing the word 'purple'.

Which things are **purple** in real life? Color them.

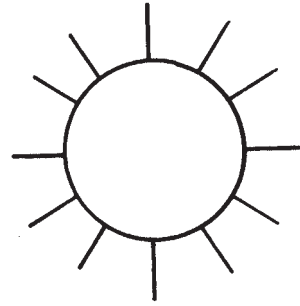
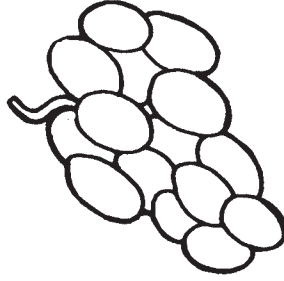
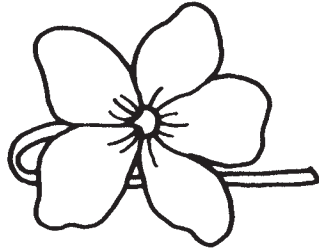

Name: _____

Color: Purple

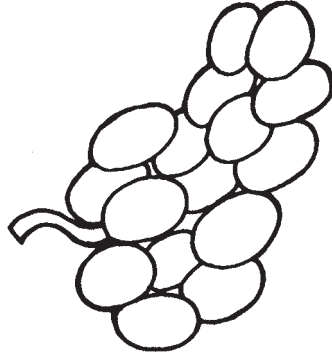
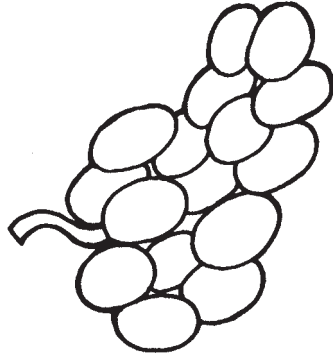
Circle each **purple**.party
quietpurple
purpleplay
purpleDraw a bunch of grapes. Color the grapes **purple**.Write **purple**.

Let's eat the _____

_____ grapes.

Name: _____

Color: Black

Trace the word. 

black



black



black



Which things are **black** in real life? Color them.

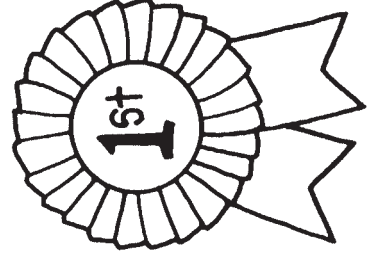
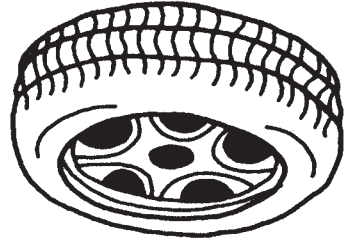
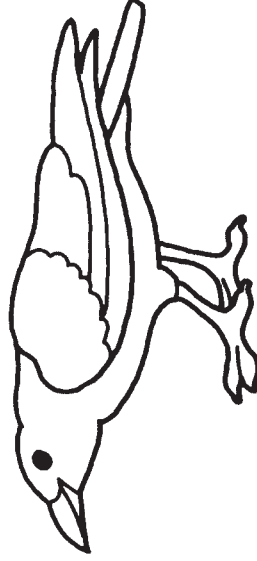
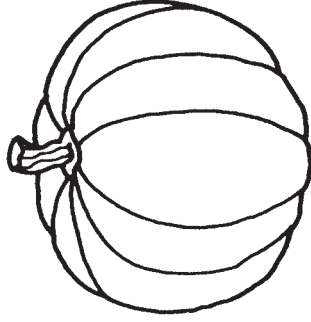
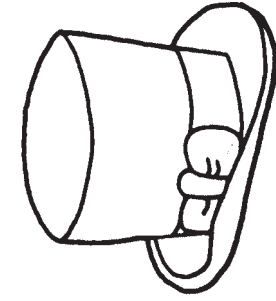

Write **black**.

Name: _____

Color: Black

Circle each **black**.

black

back

black

black

bend

ball

Draw a crow. Color each crow **black**.

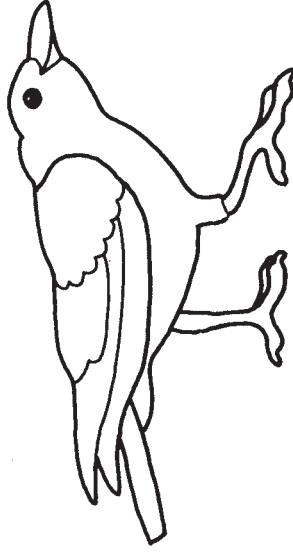

Write **black**.

I see two _____

_____ crows.

Name: _____

Color: Brown

Trace the word.



brown



brown



brown

Which things are **brown** in real life? Color them.

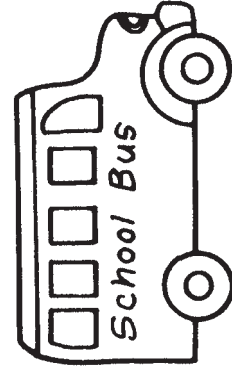
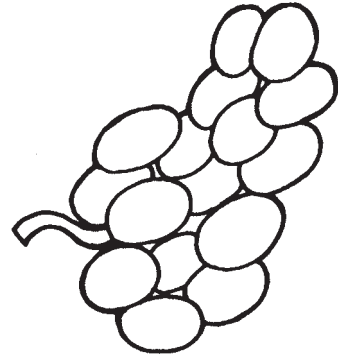
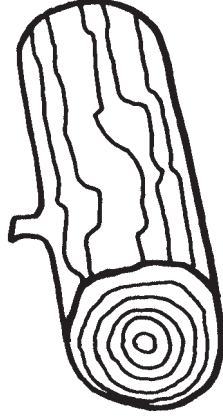
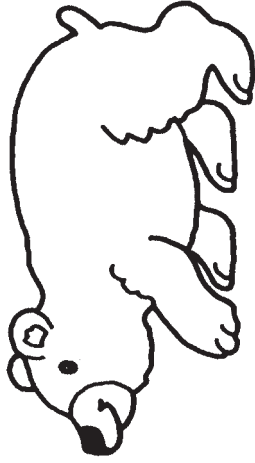
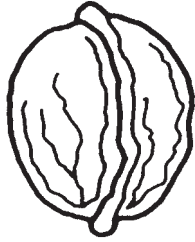

Write **brown**.

Blank handwriting lines for writing the word 'brown'.

Name: _____

Color: Brown

Circle each **brown**.

blow

brown

clown

brown

bring

brown





Draw a bear. Color each bear **brown**.Write **brown**.

The two big bears are _____.

Name: _____

Colors: Review

Color the picture. Use the Color Key.

Color Key	
 = purple	 = orange
 = brown	 = black

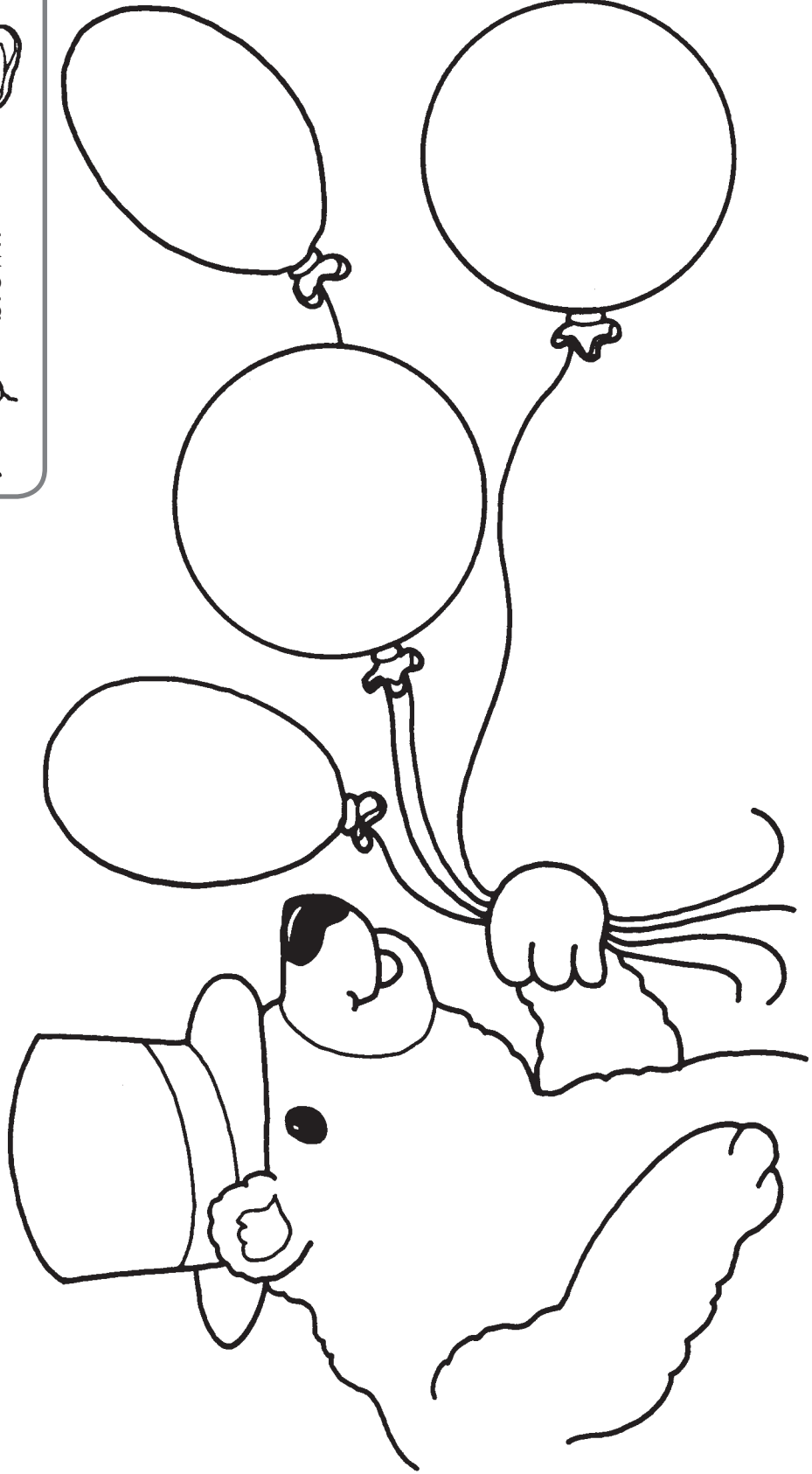

Name: _____

Colors: Review

Write the color for each picture.
Use the words in the box.
Then color the pictures.

purple black brown orange



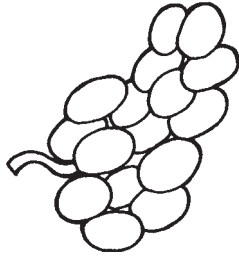

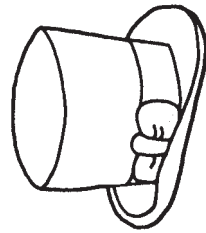

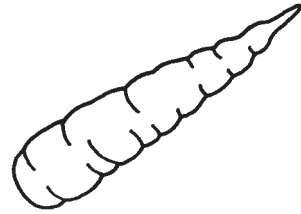

Color the picture. Use the Color Key.

Color Key



red



blue



yellow



green



orange



purple



black



brown

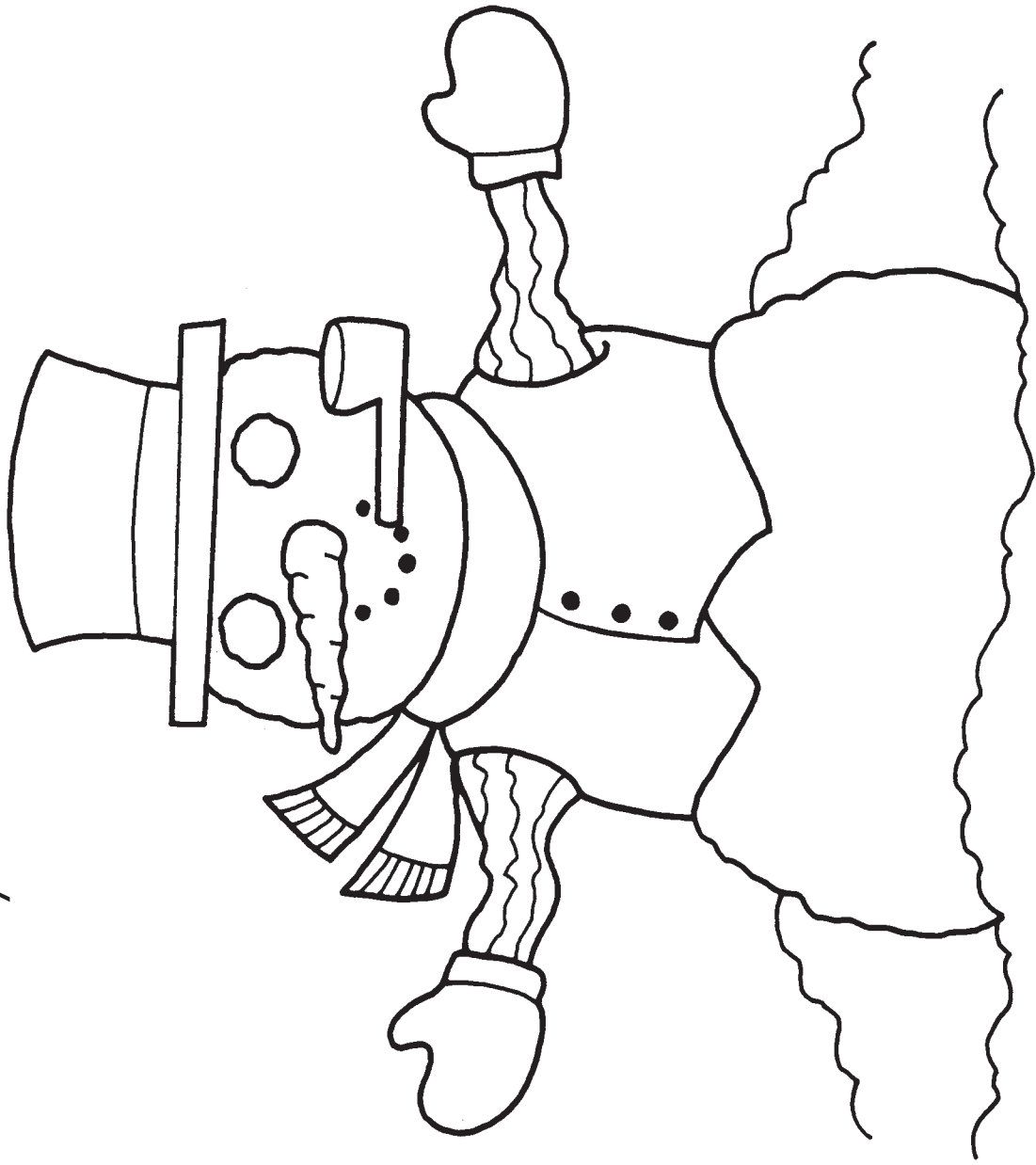

Name: _____

Color the picture. Use the Color Key.

Color Key



purple



red



orange



yellow



green



brown



black



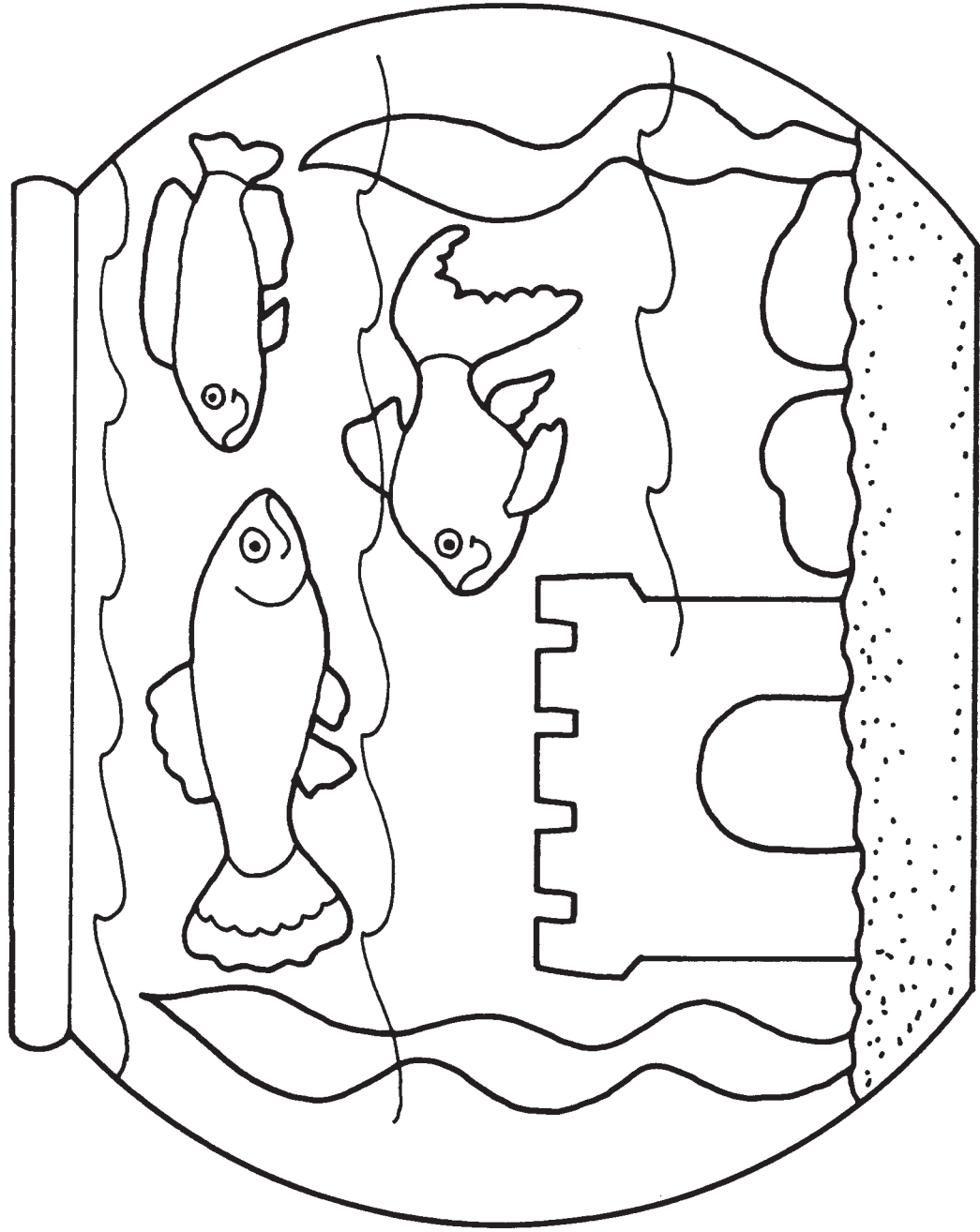

blue



Name: _____

Make a color pattern
in each row.
Use the Color Key.

Color Key		
 = red	 = blue	 = yellow

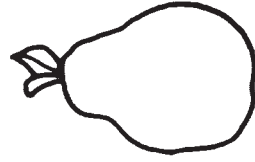
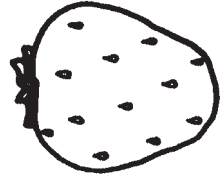
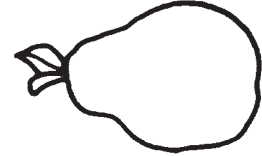
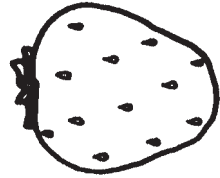
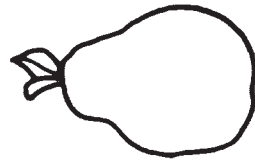
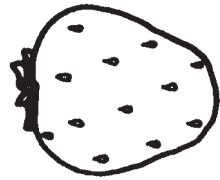
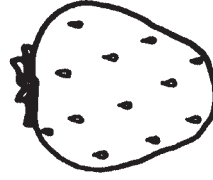
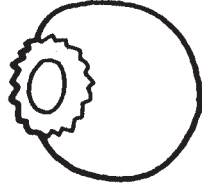
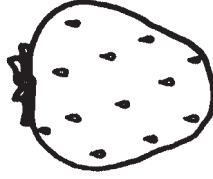
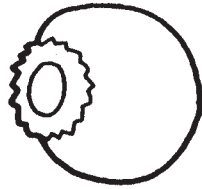
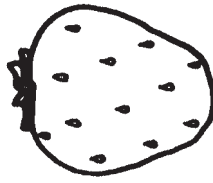
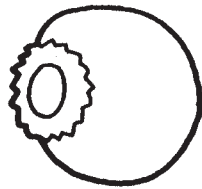
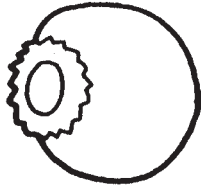
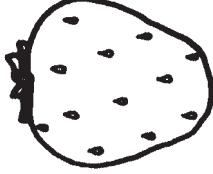
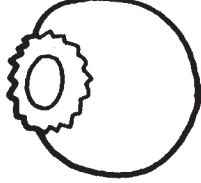
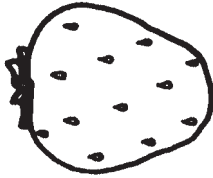
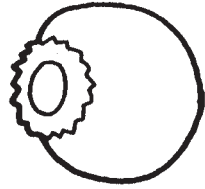
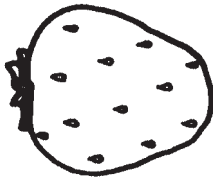

1.

2.

3.

Name: _____

Make a color pattern
in each row.
Use the Color Key.

Color Key



= red



= yellow



= green

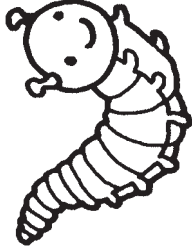
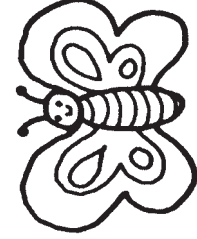
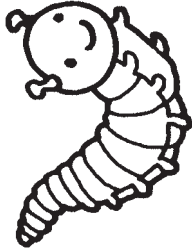
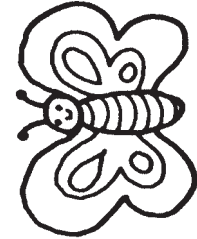
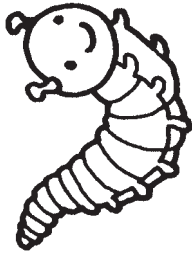
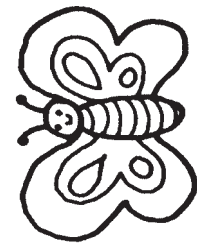

1.

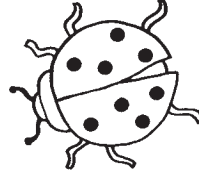
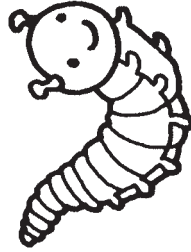
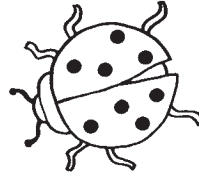
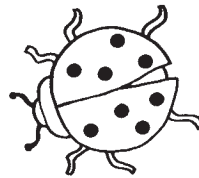

2.

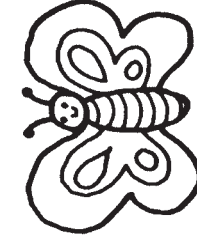
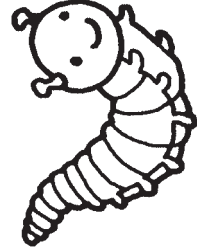
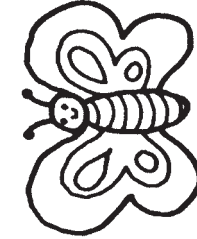
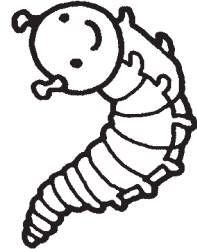
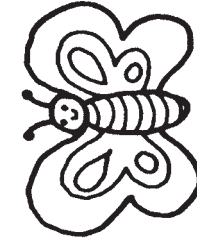
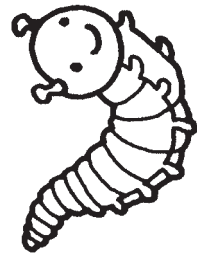

3.

Name: _____

Make a color pattern
in each row.
Use the Color Key.

Color Key



= purple



= orange



= brown

1.

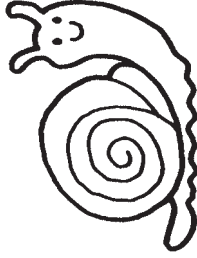
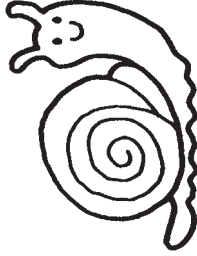
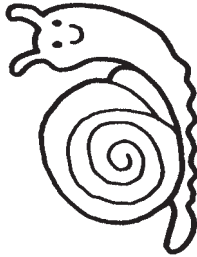

2.

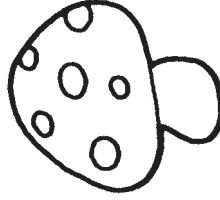
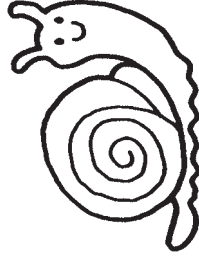
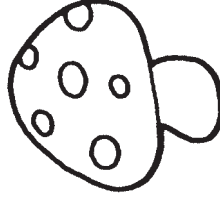
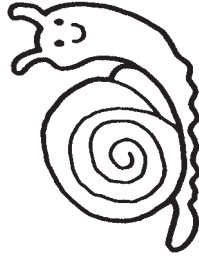
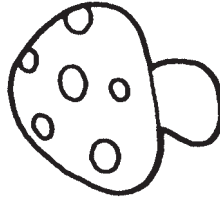

3.

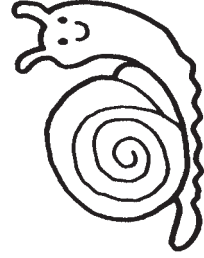
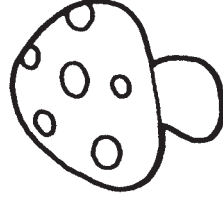
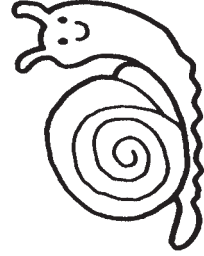
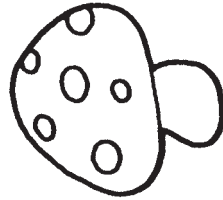
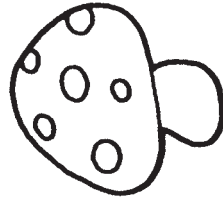

Name: _____

Color Patterns: AB

Make a color pattern
in each row.
Use the Color Key.

Color Key



= purple



= black



= brown

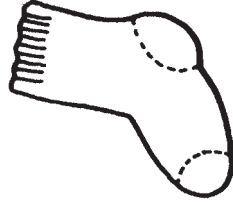
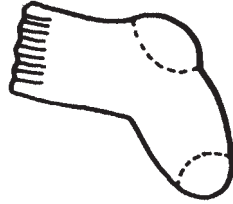
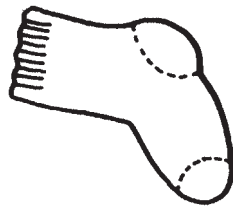
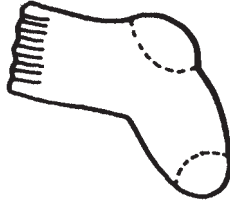
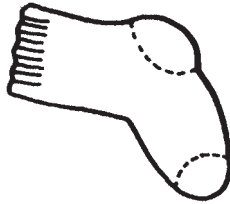
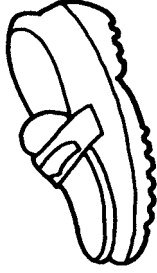
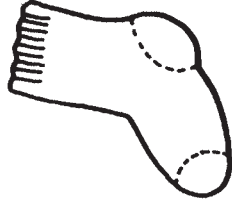
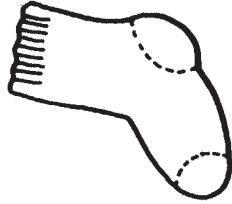
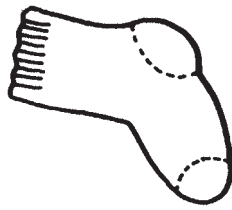

1.

2.



3.

Name: _____



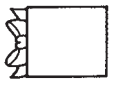

Color Patterns: AAB

Make a color pattern
in each row.
Use the Color Key.

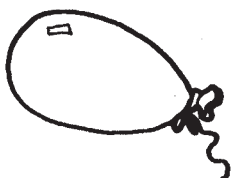
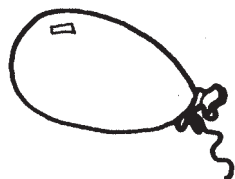
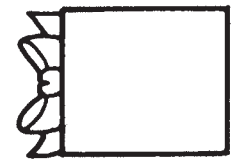
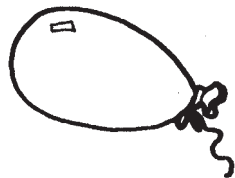
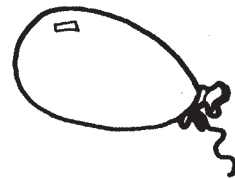
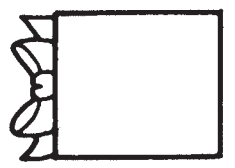
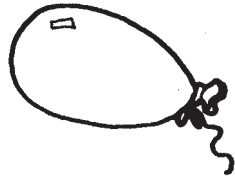
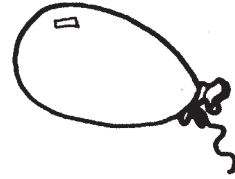
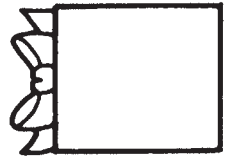
Color Key

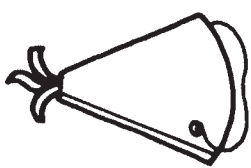
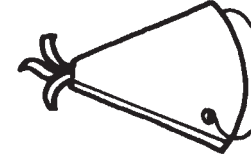
 = red	 = orange
 = blue	

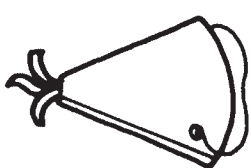
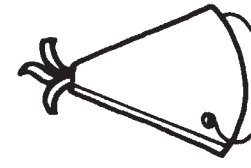
1.         

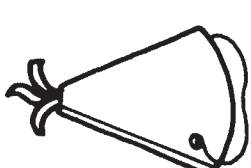
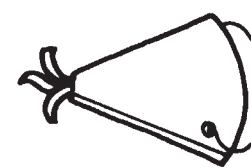
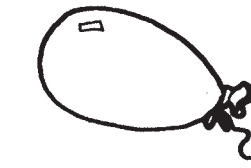
2.         

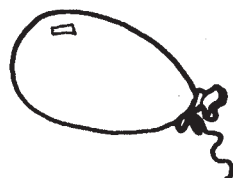
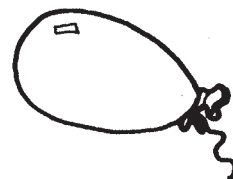
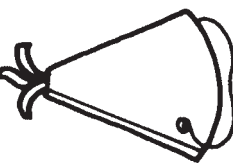
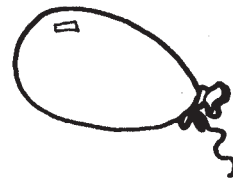
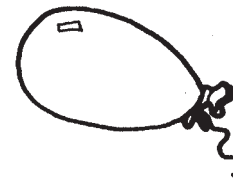
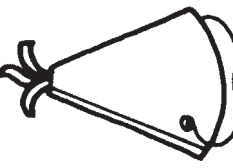
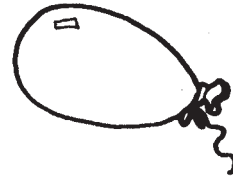
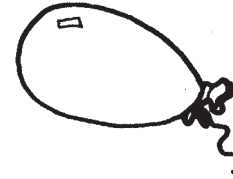
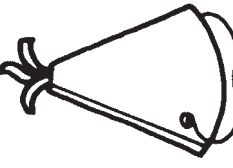
3.         









Name: _____





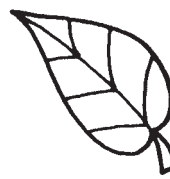



Color Patterns: AAB





Make a color pattern
in each row.
Use the Color Key.

Color Key

 = brown	 = green	 = purple
---	---	--

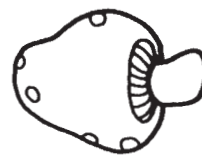
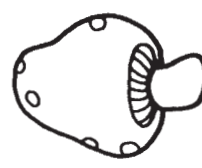
1.         

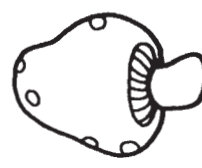
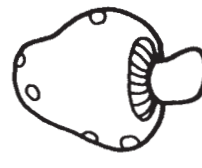
2.         

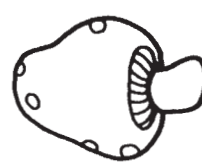
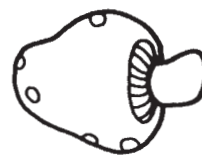
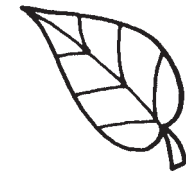
3.         

Name: _____

Color Patterns: ABB

Make a color pattern
in each row.
Use the Color Key.

Color Key

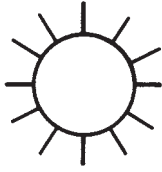
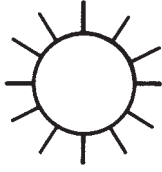
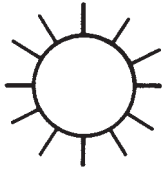
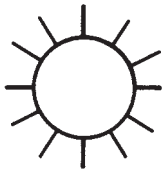
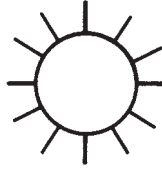
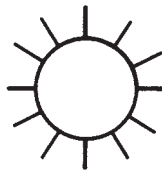
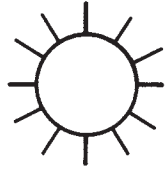
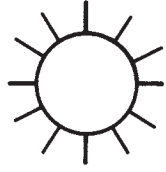
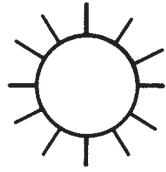
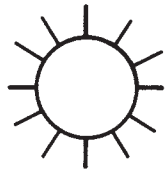
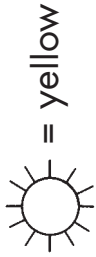

Name: _____

Color Patterns: ABB

Make a color pattern
in each row.
Use the Color Key.

Color Key

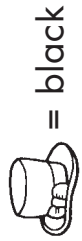

= black



= red



= purple

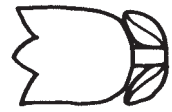
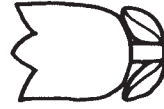
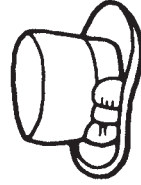
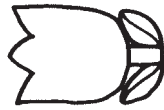
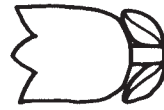
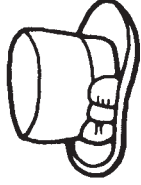
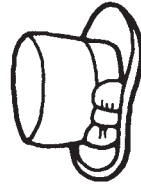
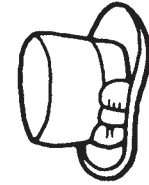
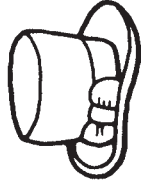
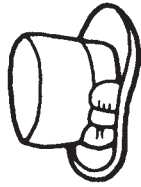

Name: _____

Color Patterns: AABB

Make a color pattern
in each row.
Use the Color Key.

Color Key













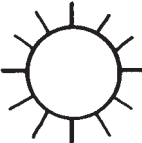

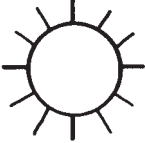

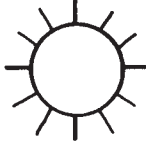
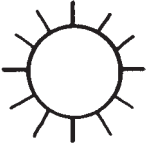











= green



= red

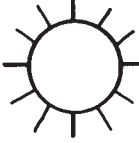
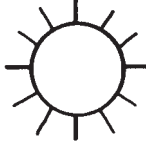

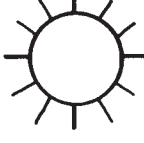
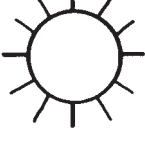
= yellow



1.								
2.								
3.								
4.								











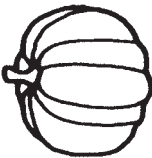

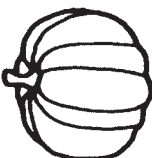



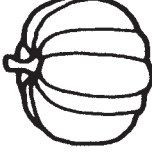
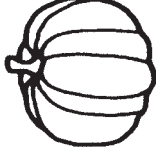

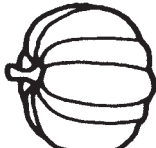

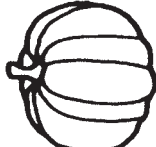

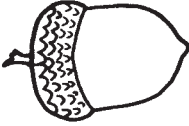
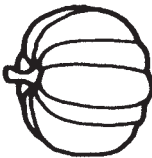
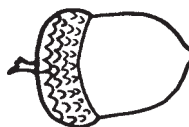

Name: _____

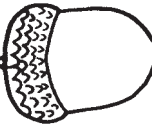
Color Patterns: AABB

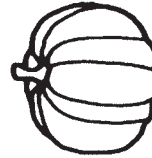
Make a color pattern
in each row.
Use the Color Key.

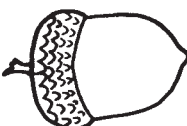
Color Key

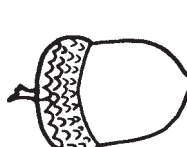
	= blue		= orange		= brown
---	--------	---	----------	---	---------

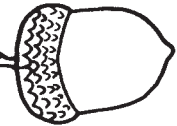
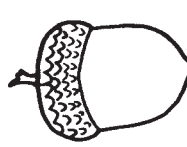
1.								
2.								
3.								
4.								

Name: _____

Make a color pattern
in each row.
Use the Color Key.

Color Key



= purple



= brown



= yellow

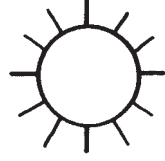
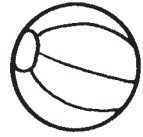
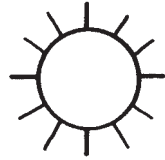
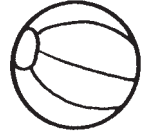
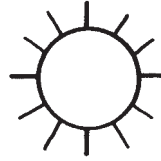
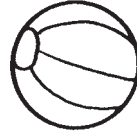
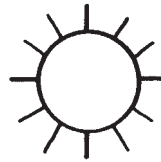
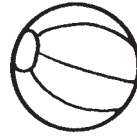
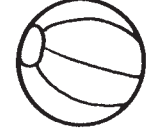
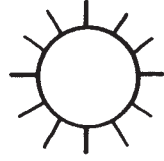
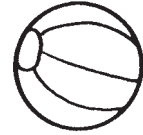
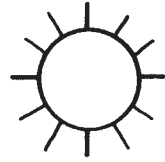
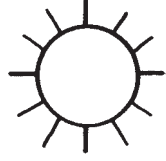
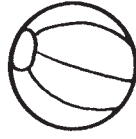
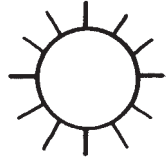
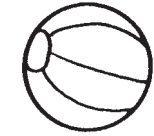

1.

2.

3.

4.

Name: _____

Make a color pattern
in each row.
Use the Color Key.

Color Key



= red



= orange



= yellow

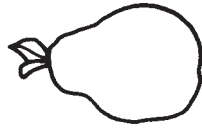

1.

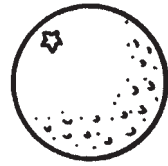
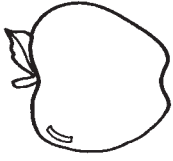
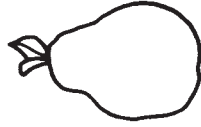
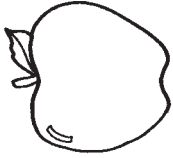

2.

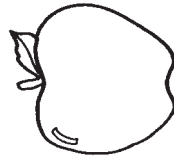
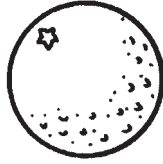
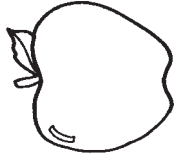
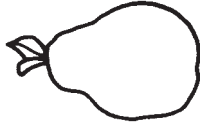

3.

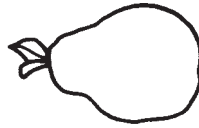
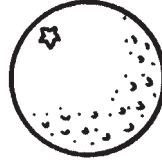
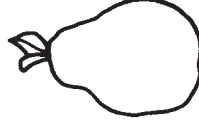
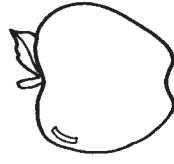
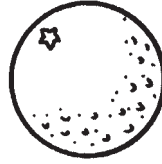
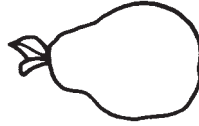

4.

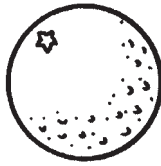
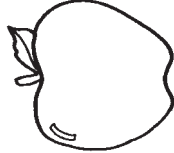
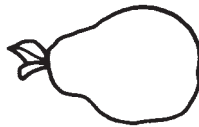
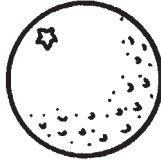
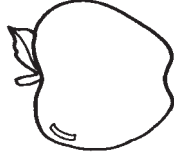

Name: _____

Shape: Circle

Trace each **circle**.

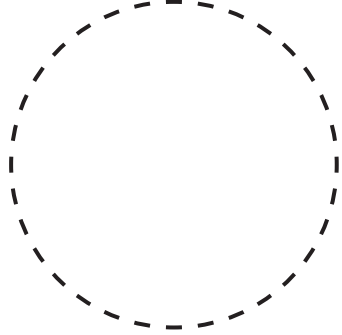
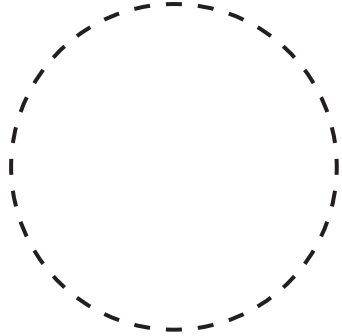
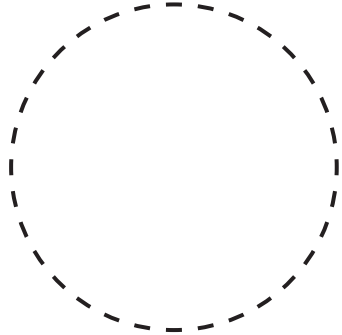
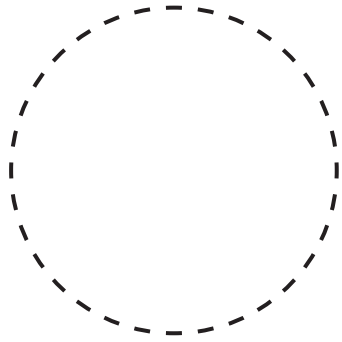

Color each **circle**.

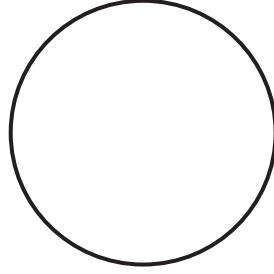
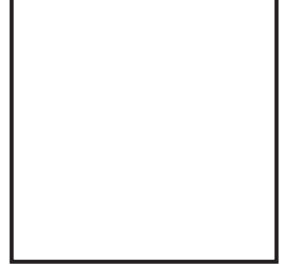
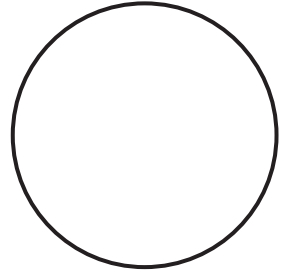
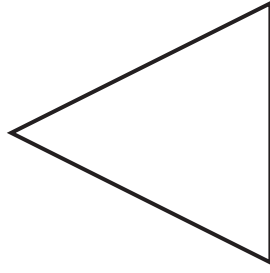
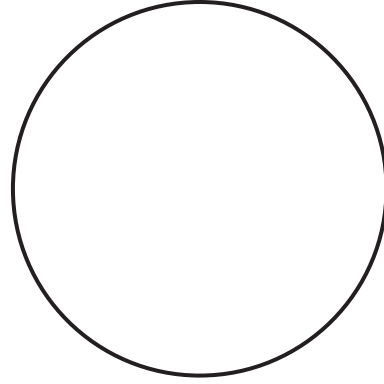
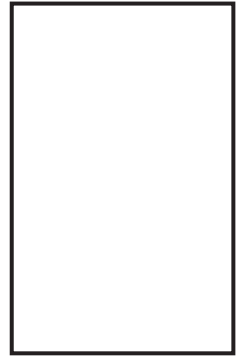
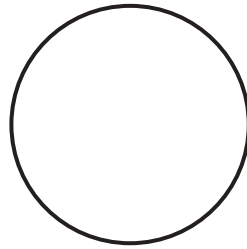

Name: _____

Shape: Circle

Trace the word.



circle

circle

circle

Trace each **circle**.

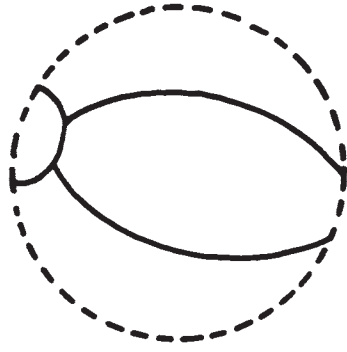
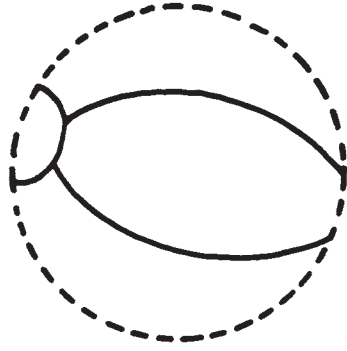

Draw a ○ for a ball.

Write **circle**.

Blank handwriting lines for writing the word 'circle'.

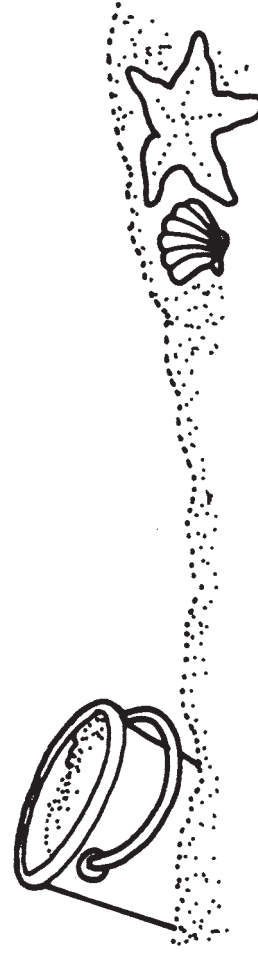



Name: _____

Shape: Square

Trace each **square**.



Color each **square**.

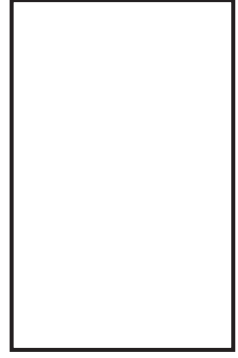
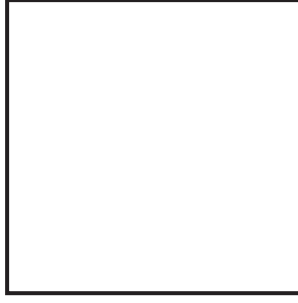
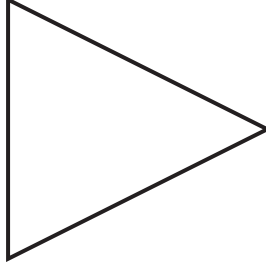
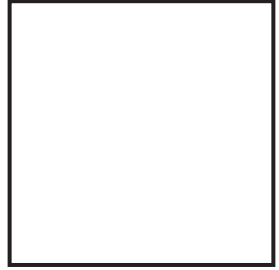
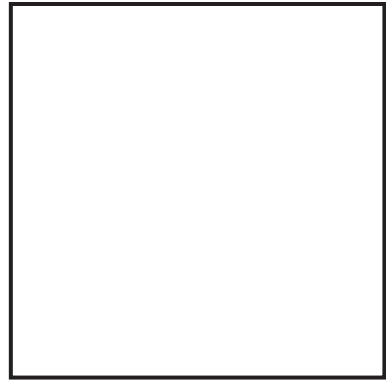
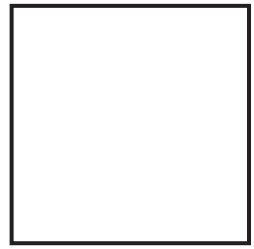
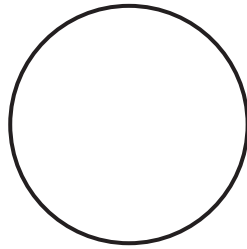



Name: _____

Shape: Square

Trace the word.

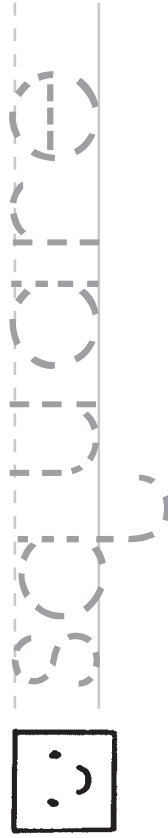
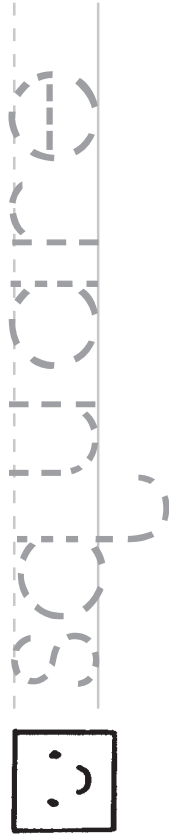
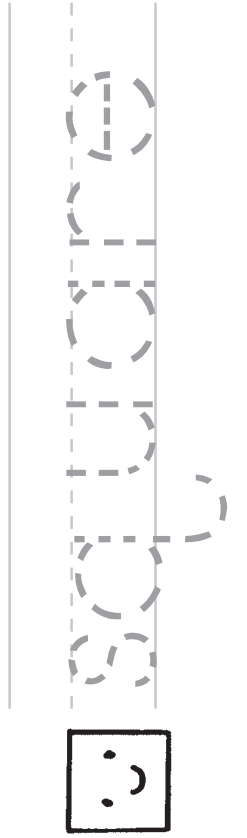
Write **square**.

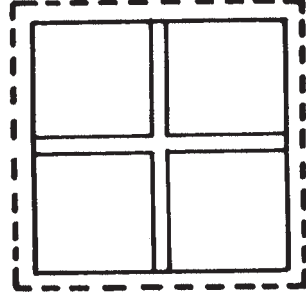
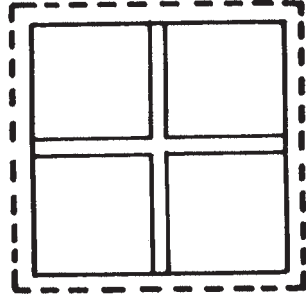
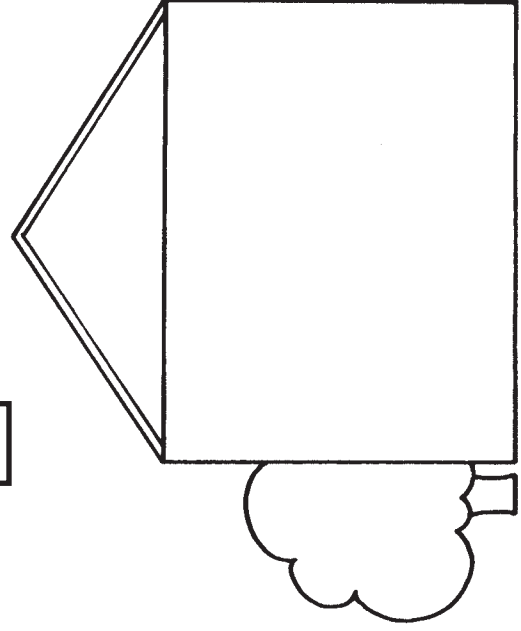
Trace each **square**.Draw a  for a window.

Name: _____

Shape: Triangle

Trace each **triangle**.

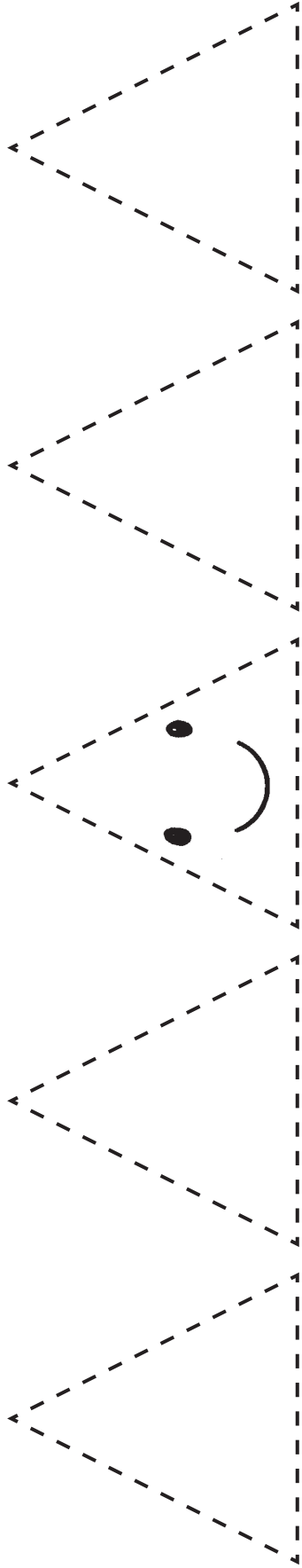

Color each **triangle**.

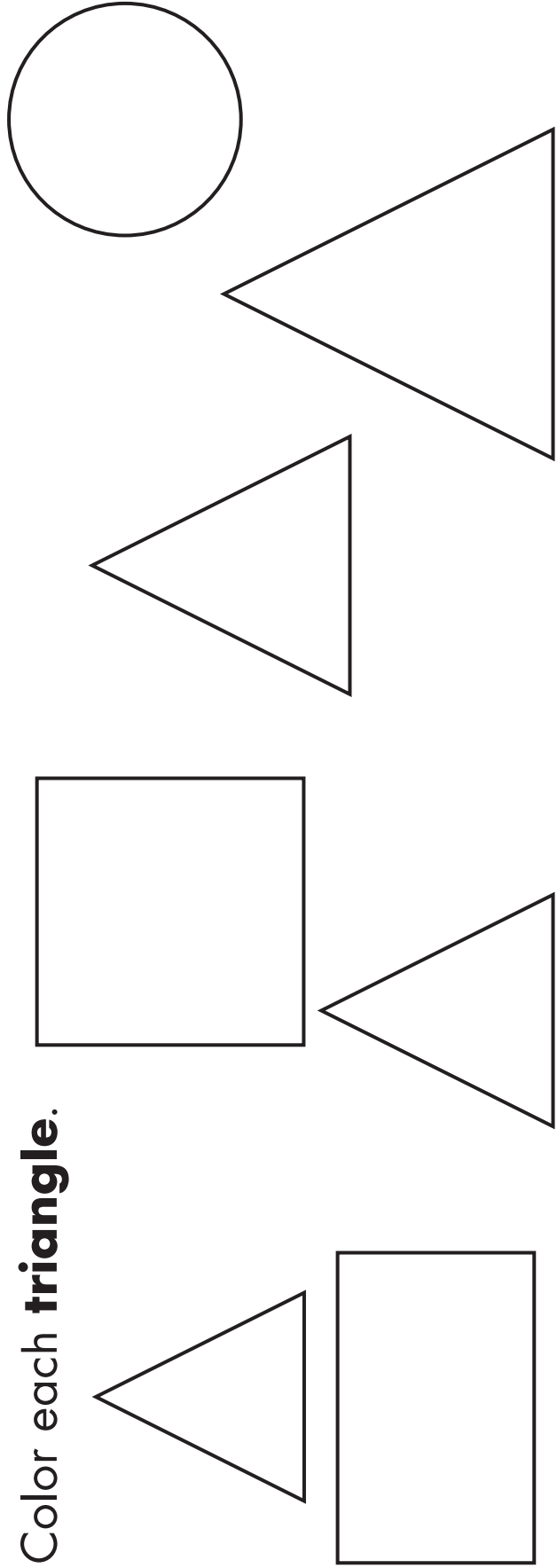

Name: _____

Shape: Triangle

Trace the word.



triangle



triangle



triangle

Trace each **triangle**.

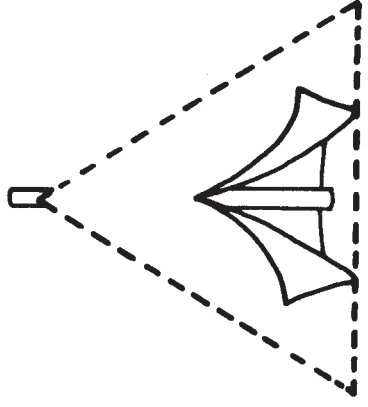
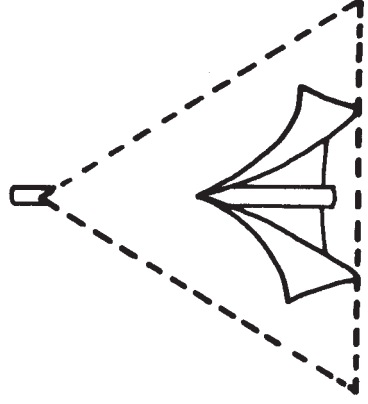

Draw a  for a tent.

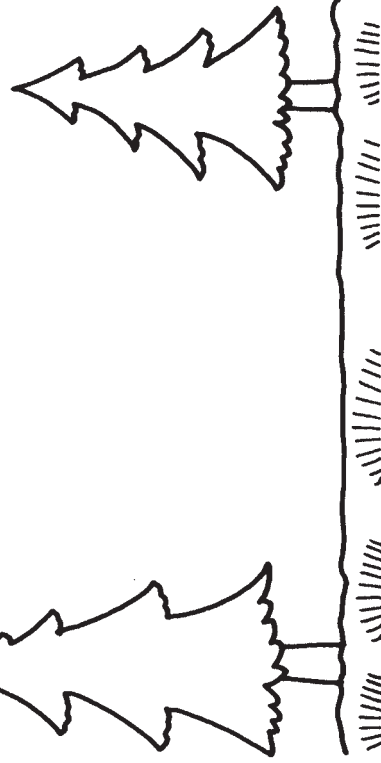
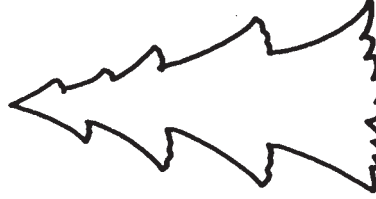

Write **triangle**.



Name: _____

Shape: Rectangle

Trace each **rectangle**.

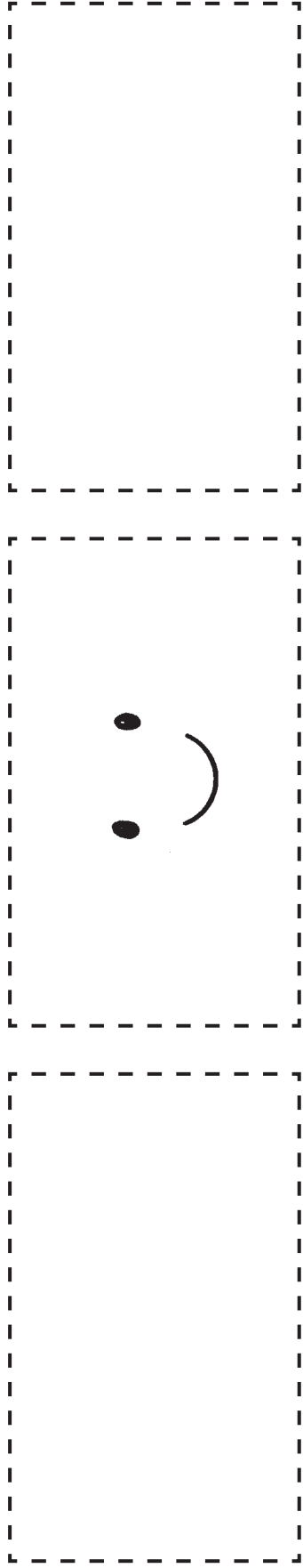

Color each **rectangle**.

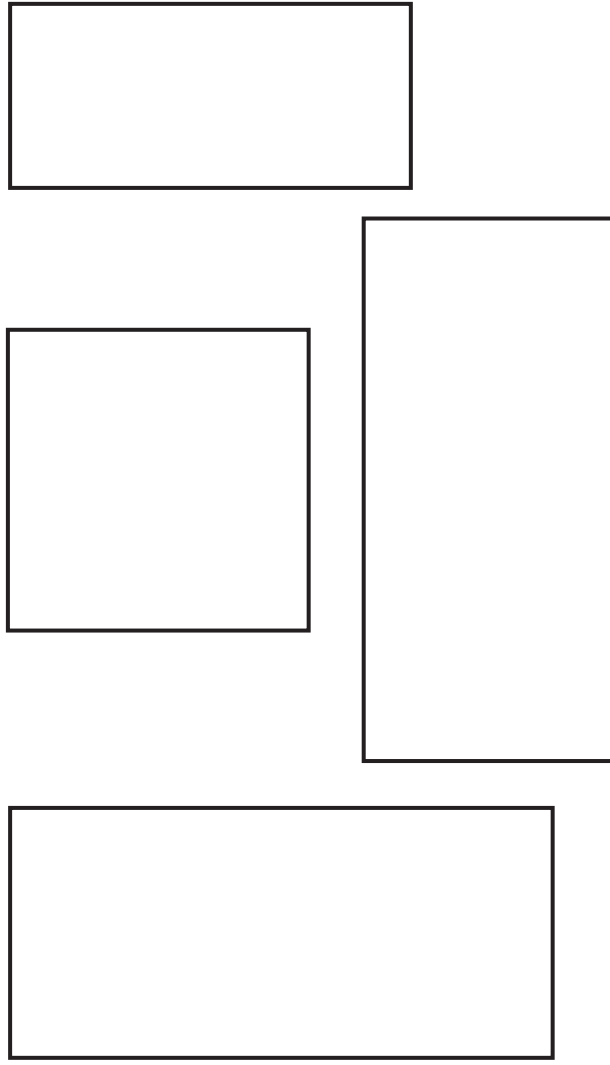
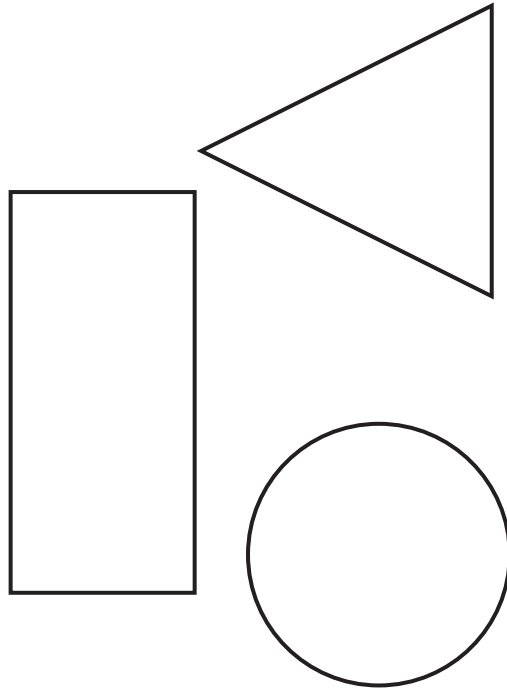

Name: _____

Shape: Rectangle



Trace the word.

rectangle

rectangle

rectangle

Trace each **rectangle**.

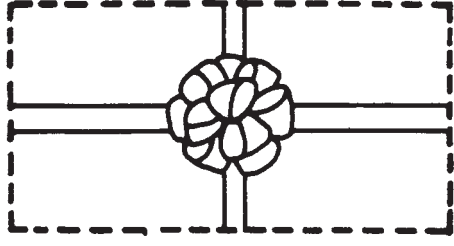
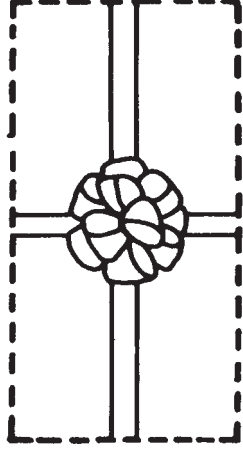

Draw a  for a gift.



Write **rectangle**.

Blank lines for writing the word 'rectangle'.

Name: _____

Color the picture. Use the Color Key.

Color Key	
○	green
□	red
△	blue
□	brown

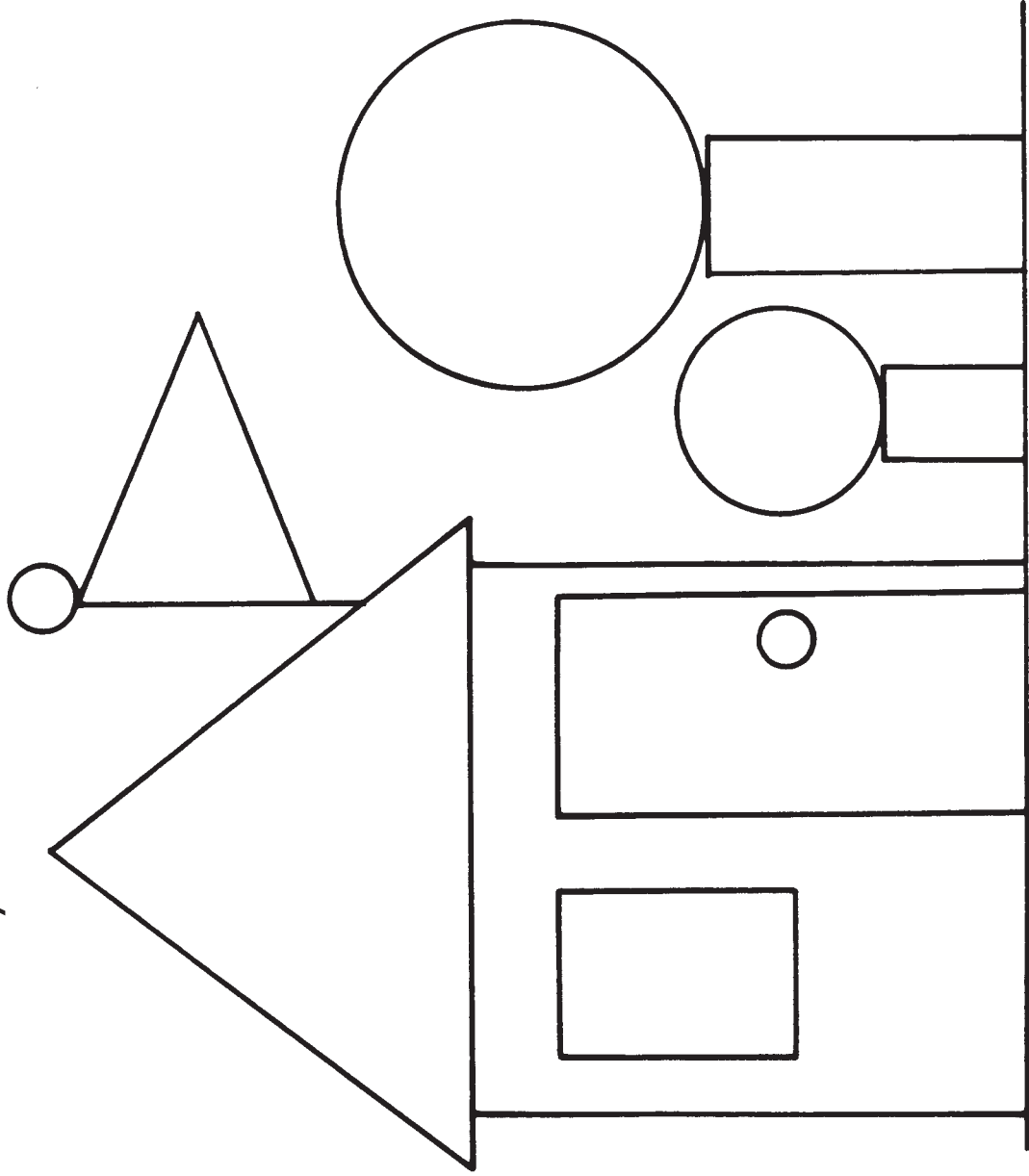



Name: _____

Shapes: Review

Write the name for each shape.
Use the words in the box.

square circle rectangle triangle



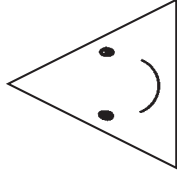

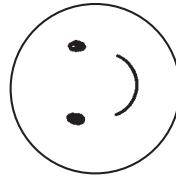

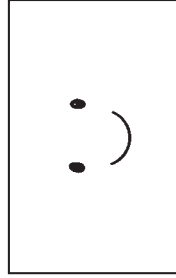

Name: _____

Shape: Oval

Trace each **oval**.

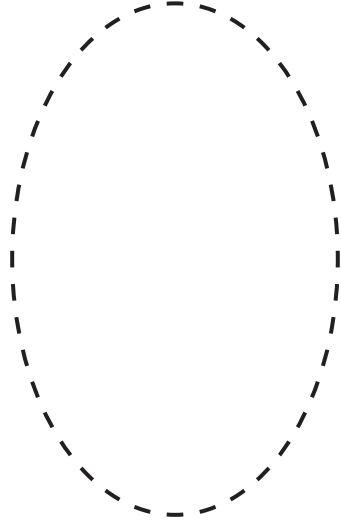
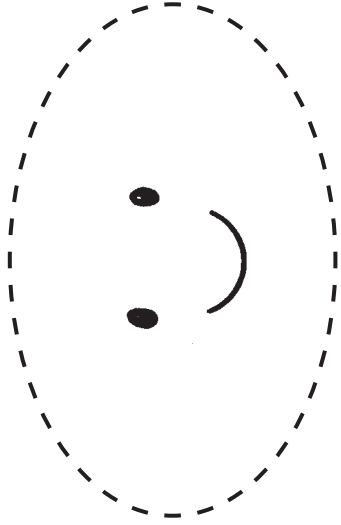
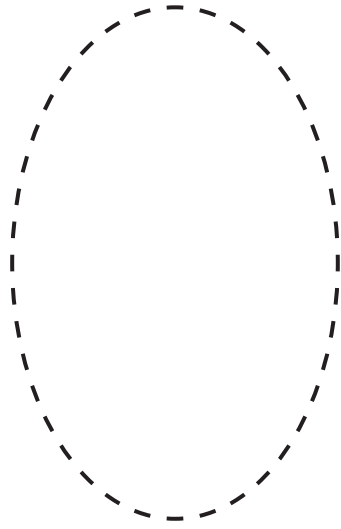

Color each **oval**.

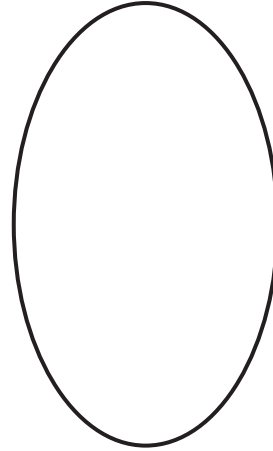
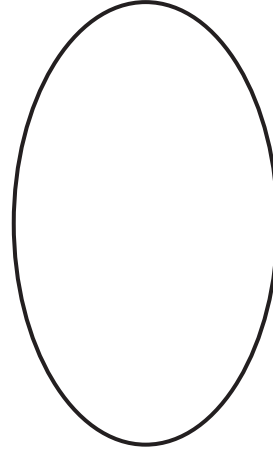
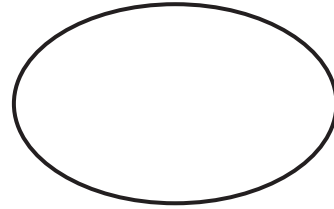
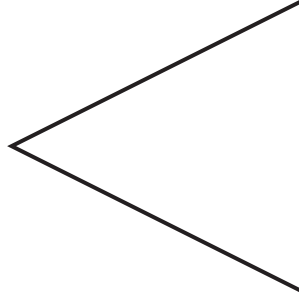
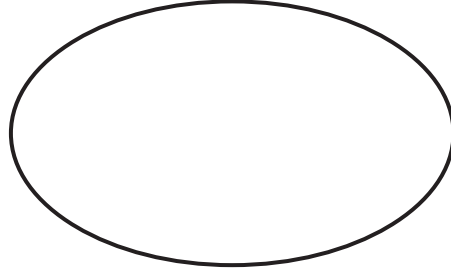
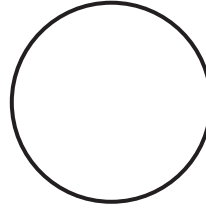

Name: _____

Shape: Oval

Trace the word.



oval



oval



oval

Trace each **oval**.



Draw an  for a pond.



Write **oval**.

Three horizontal lines for writing: a solid top line, a dashed middle line, and a solid bottom line.

Name: _____

Shape: Octagon

Trace each **octagon**.

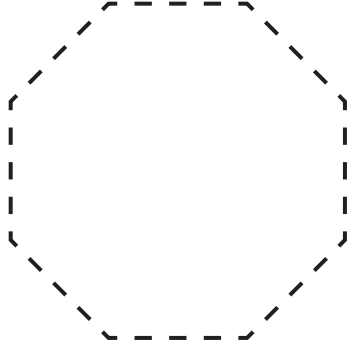
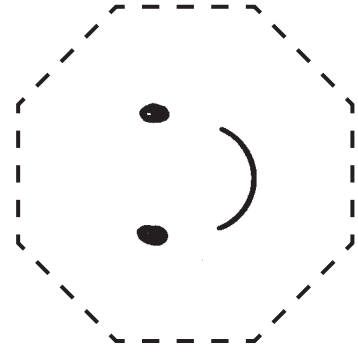
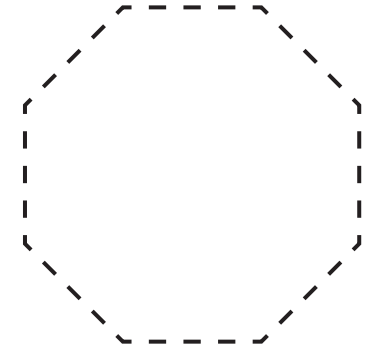
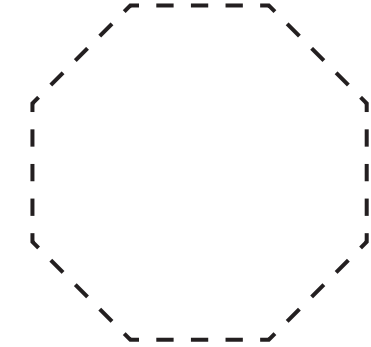

Color each **octagon**.

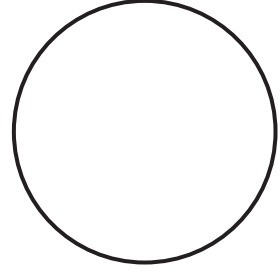
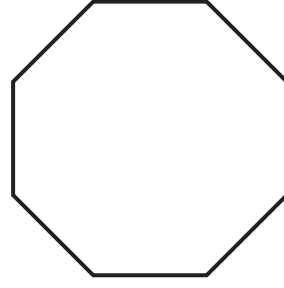
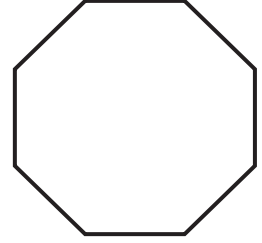
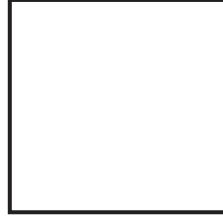
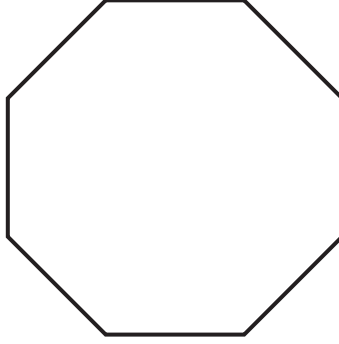
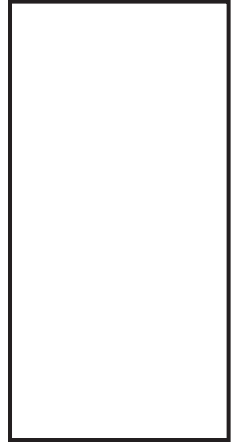
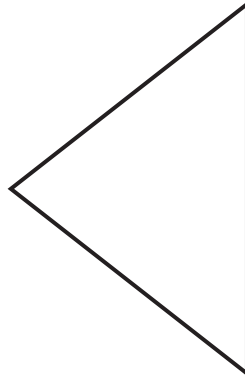
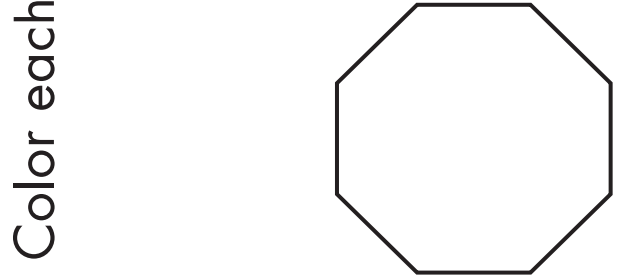

Name: _____

Shape: Octagon

Trace the word.



octagon



octagon



octagon

Trace each **octagon**.

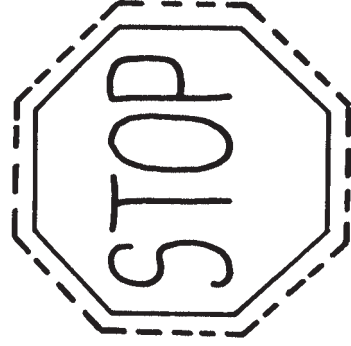
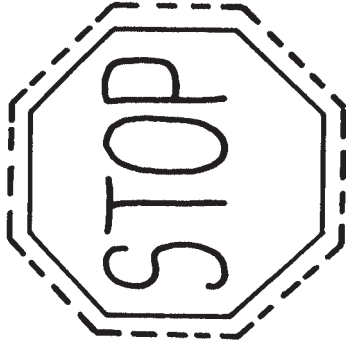

Draw a  as a sign on the post.

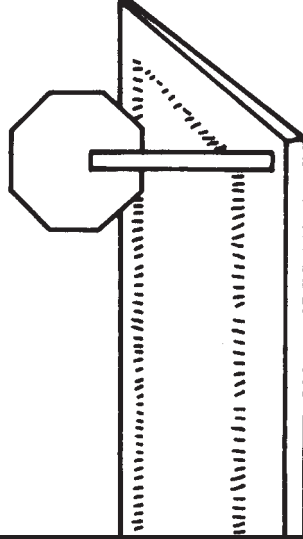

Write **octagon**.

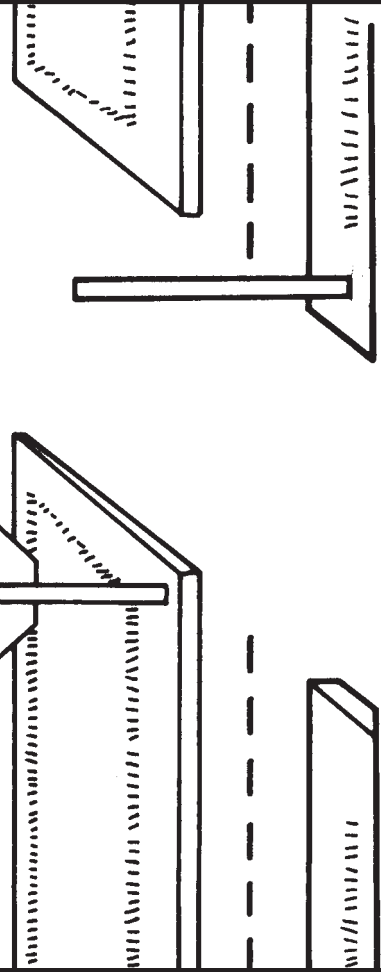

Name: _____

Shape: Star

Trace each **star**.

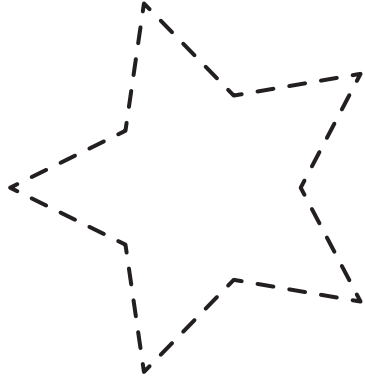
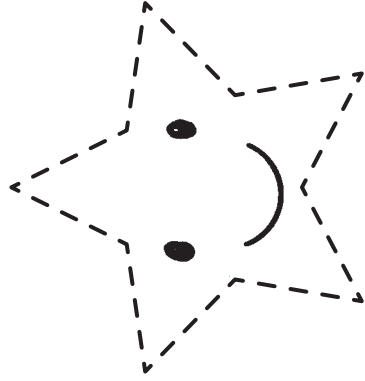
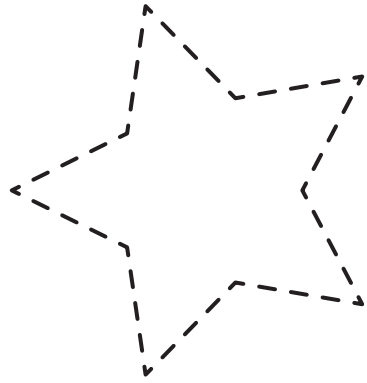
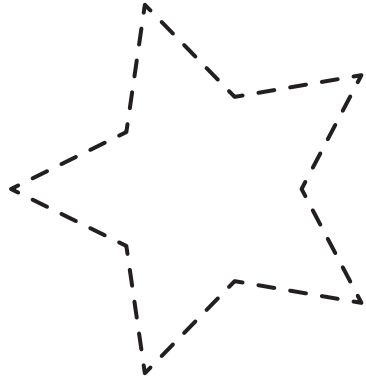

Color each **star**.

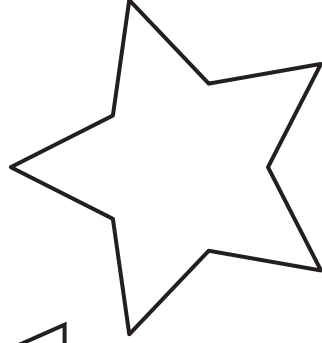
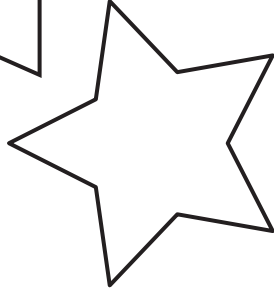
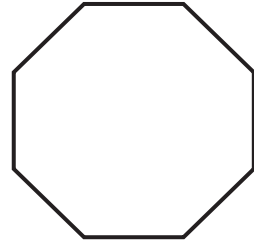
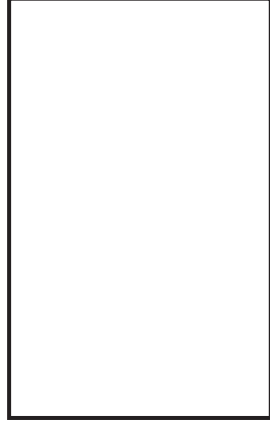
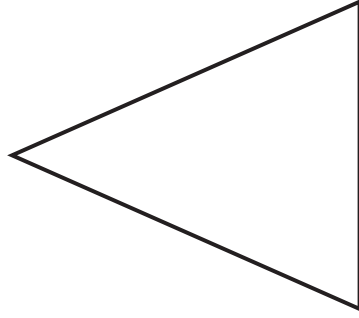
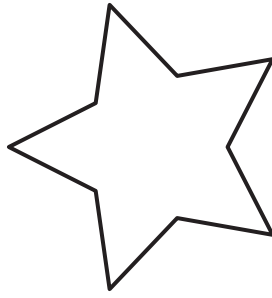
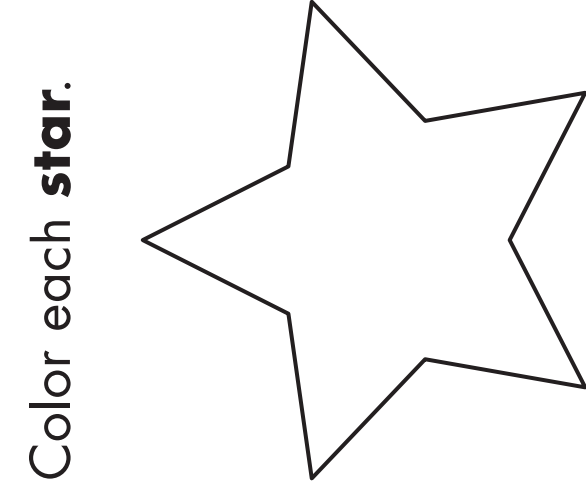

Name: _____

Shape: Star

Trace the word.



☆☆☆ star

☆☆☆ star

☆☆☆ star

Trace each **star**.

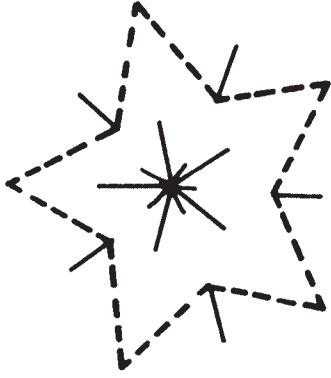
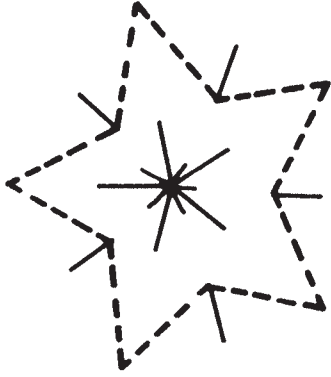

Draw a ☆ in the sky.

*

*

*

*

*

*

Write **star**.

Blank handwriting lines for writing the word 'star'.



Name: _____

Shape: Diamond

Trace each **diamond**.

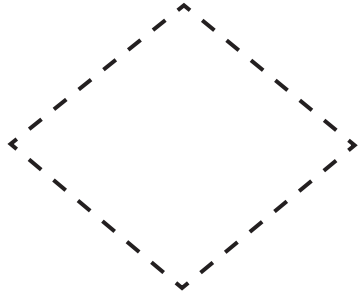
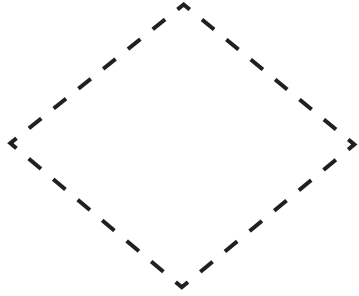
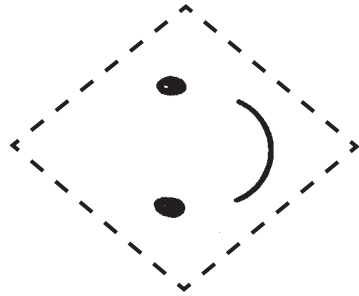
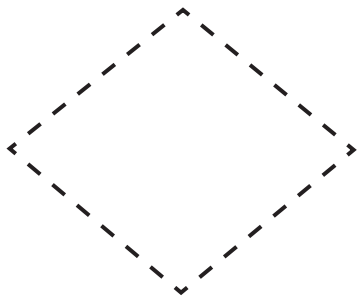
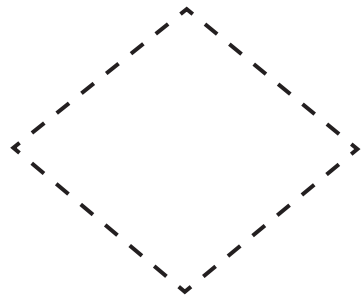

Color each **diamond**.

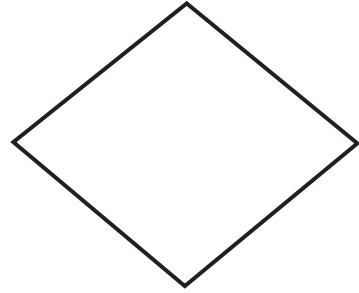
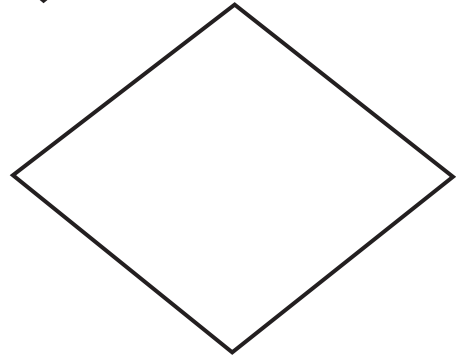
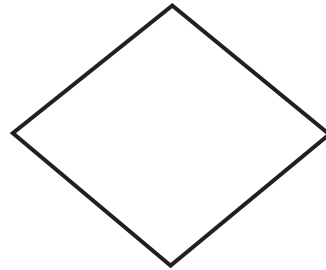
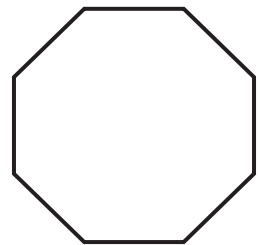
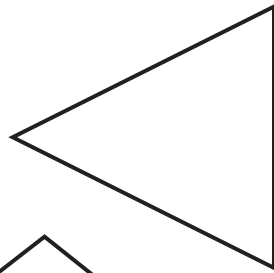
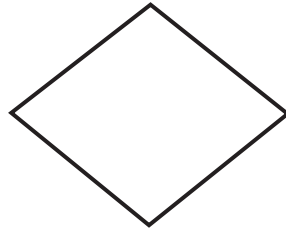

Name: _____

Shape: Diamond

Trace the word.



diamond



diamond



diamond

Trace each **diamond**.

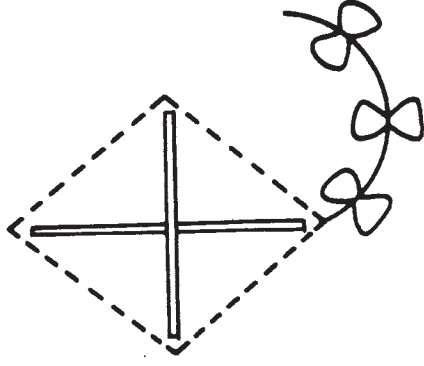
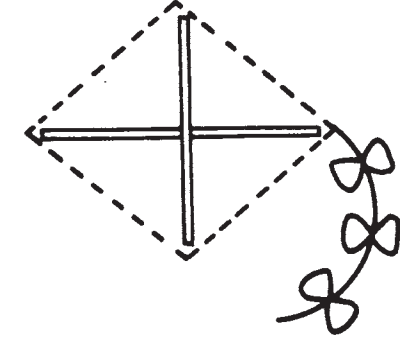

Draw a  for a kite.

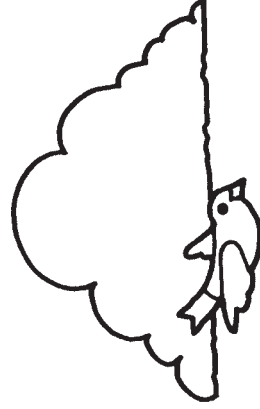





Write **diamond**.

Blank writing lines for the word 'diamond'.

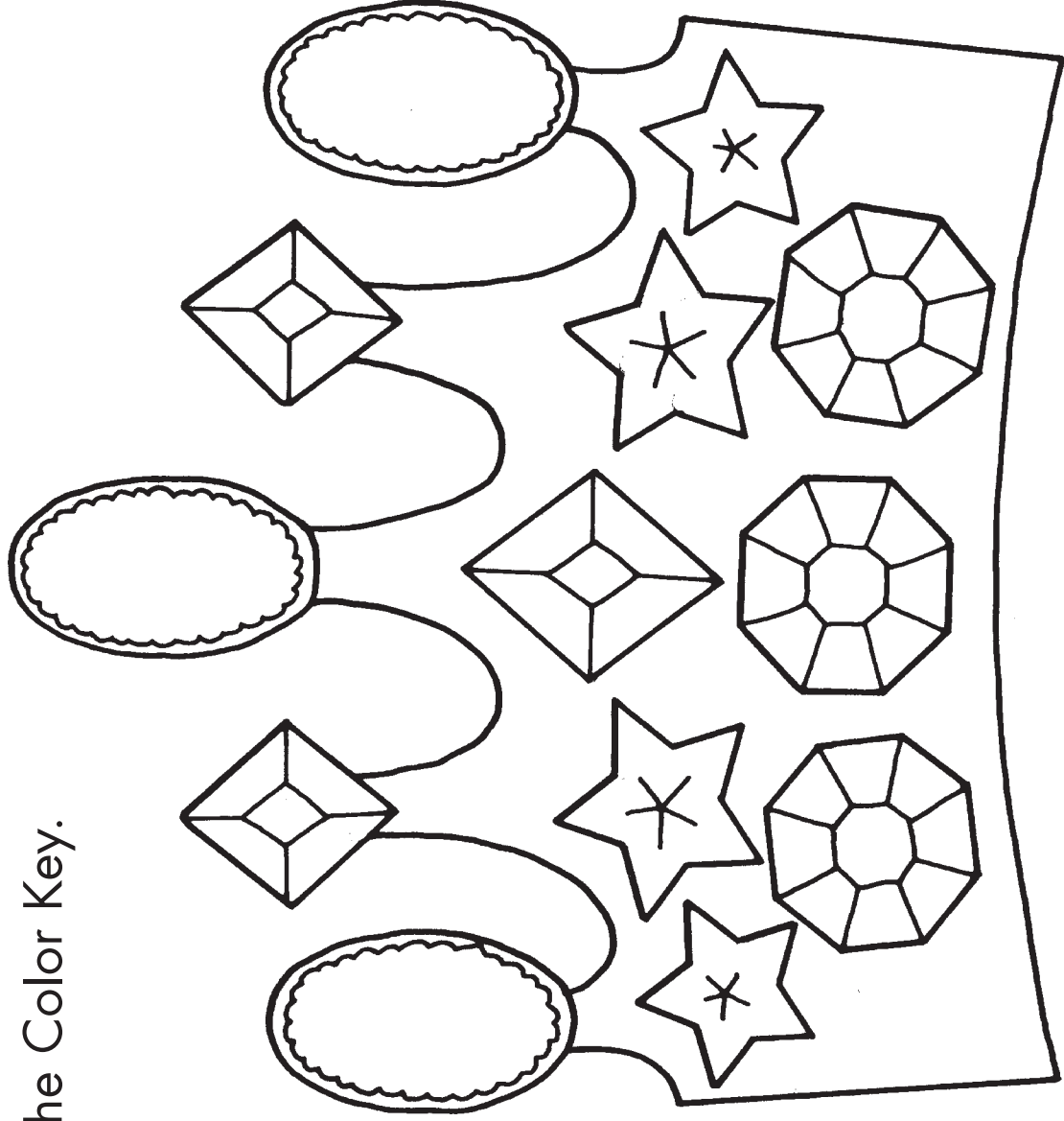
Name: _____

Color the picture. Use the Color Key.



Color Key	
	blue
	red
	yellow
	green

Write the name for each shape.
Use the words in the box.

octagon oval diamond star



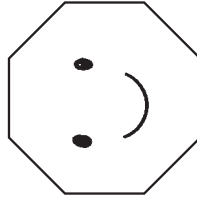

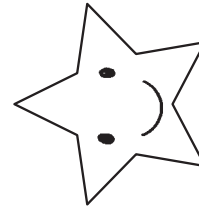

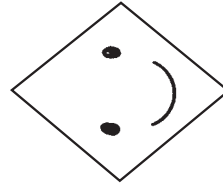

Name: _____

Draw shapes to complete each pattern.

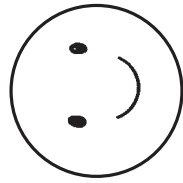

1.

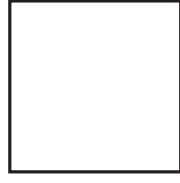
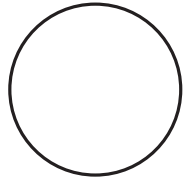
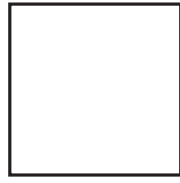

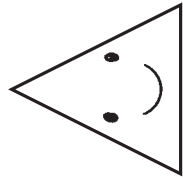

2.

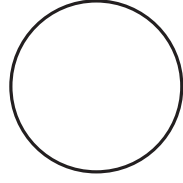
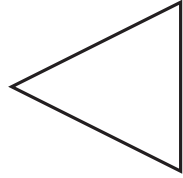
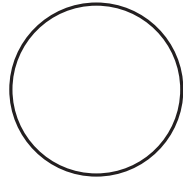

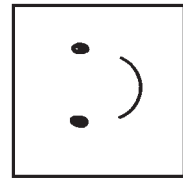

3.

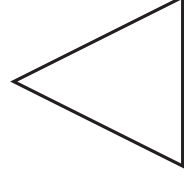
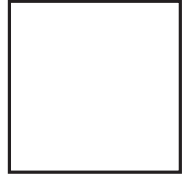
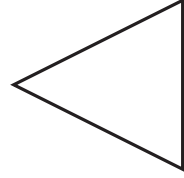

Name: _____

Draw shapes to complete each pattern.

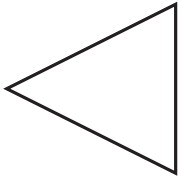
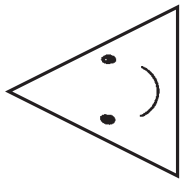

1.

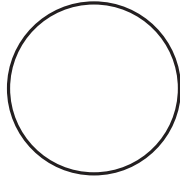
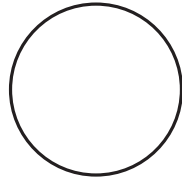

2.

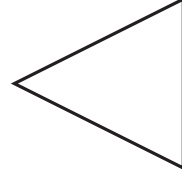
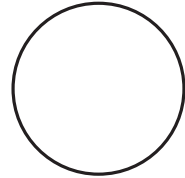
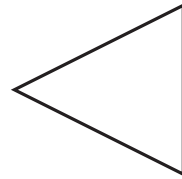
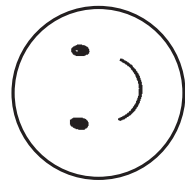



3.

Name: _____

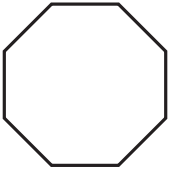
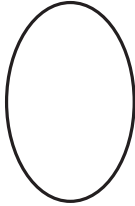
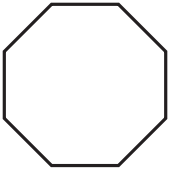
Draw shapes to complete each pattern.

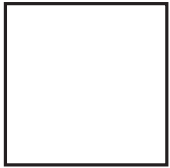
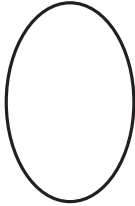
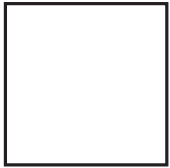
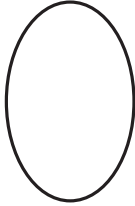
1.     _____

2.      _____

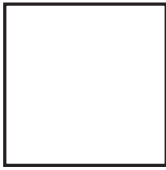
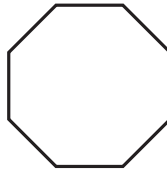
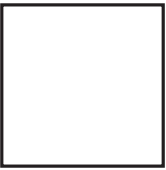
3.     _____

Name: _____

Draw shapes to complete each pattern.

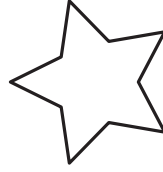
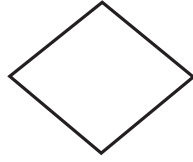
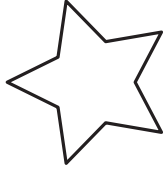
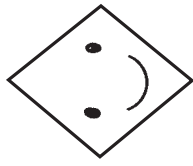

1.

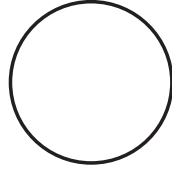
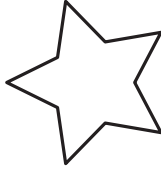
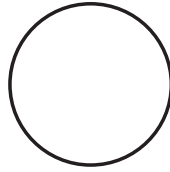
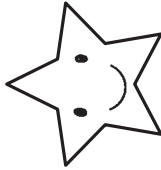

2.

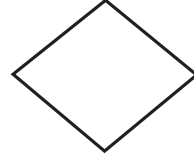
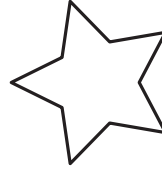
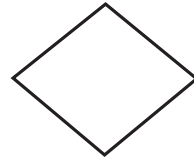
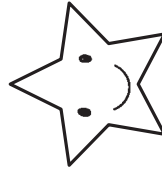

3.

Name: _____

Shape Patterns: AAB

Draw shapes to complete each pattern.

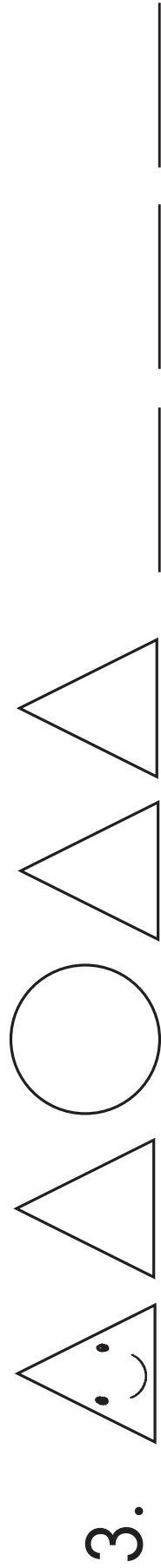
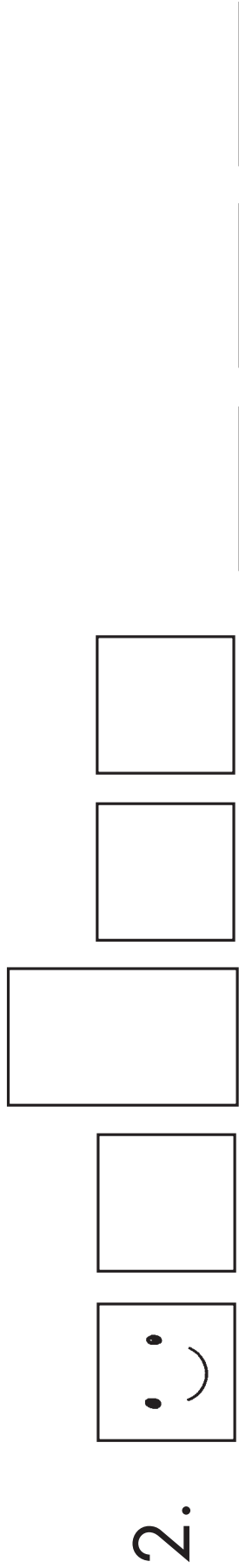
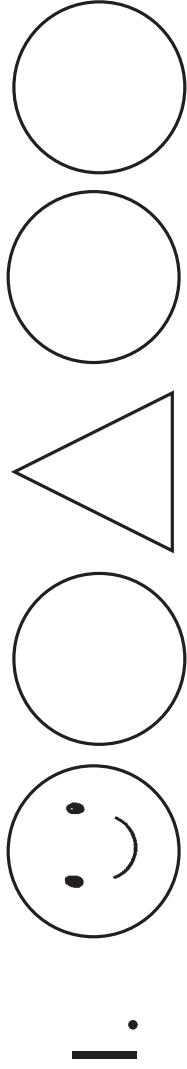

Name: _____

Shape Patterns: AAB

Draw shapes to complete each pattern.

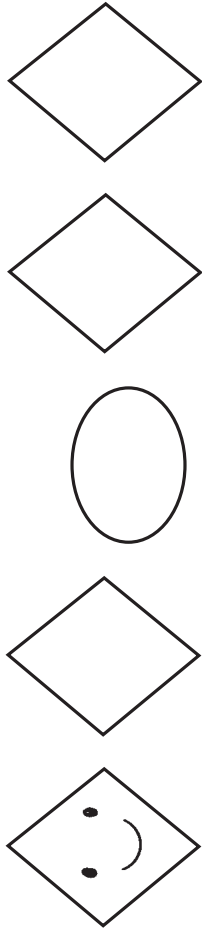
1.  _____

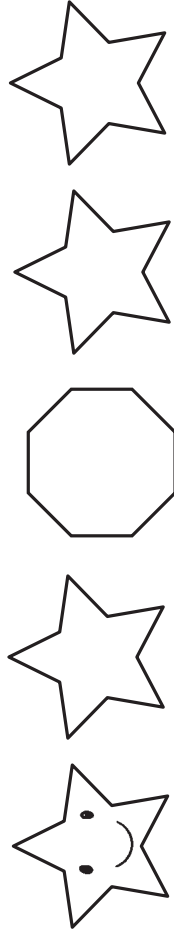
2.  _____

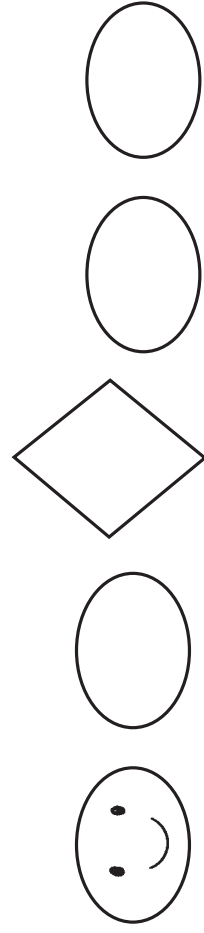
3.  _____

Draw shapes to complete each pattern.

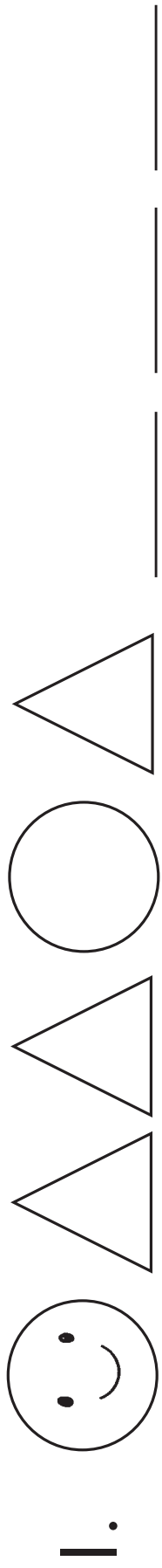
1. 

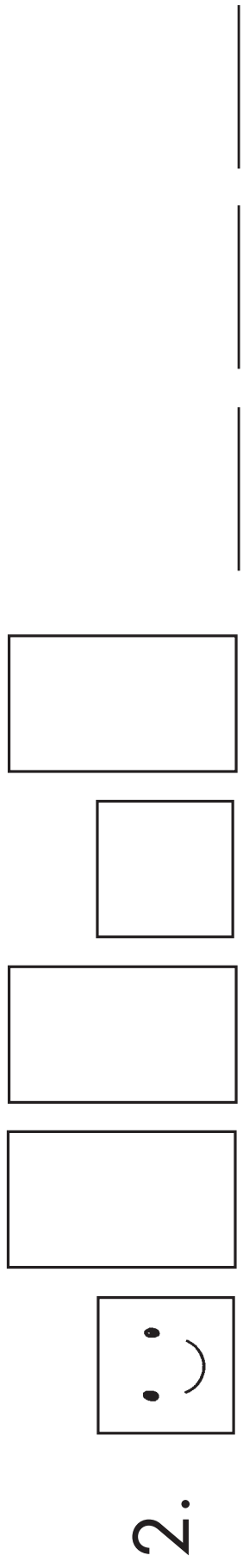
2. 

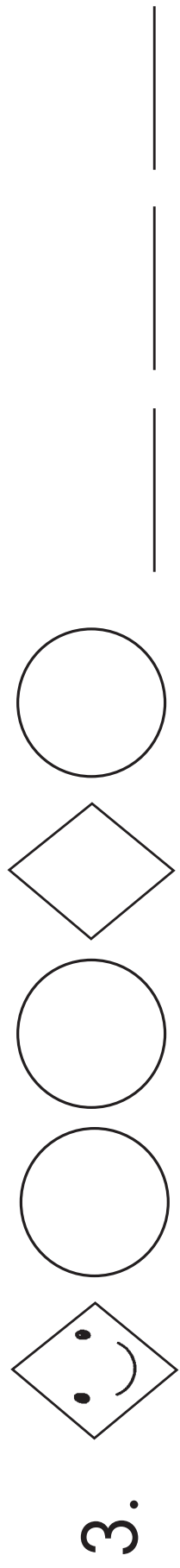
3. 

Name: _____

Shape Patterns: ABB

Draw shapes to complete each pattern.

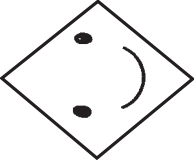
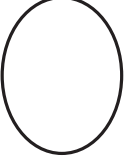
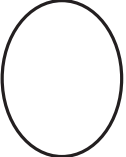
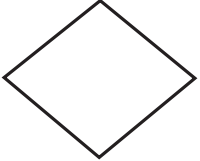
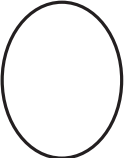
1.     

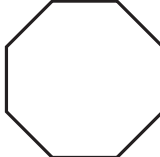
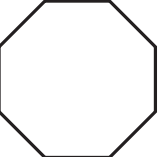
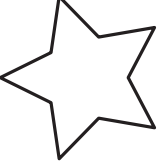
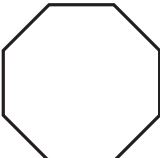
2.     

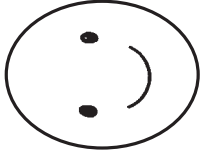
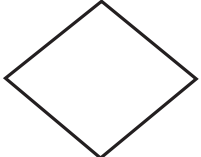
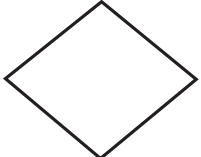
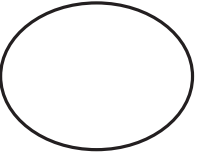
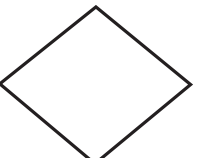
3.     

Name: _____

Shape Patterns: AABB

Draw shapes to complete each pattern.

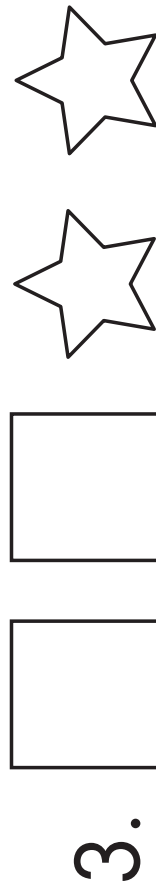
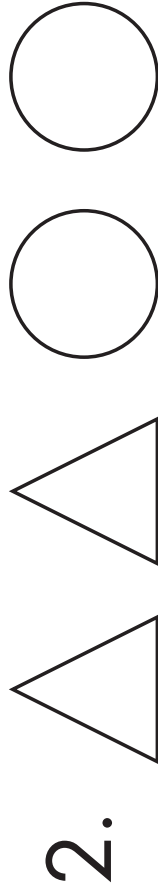
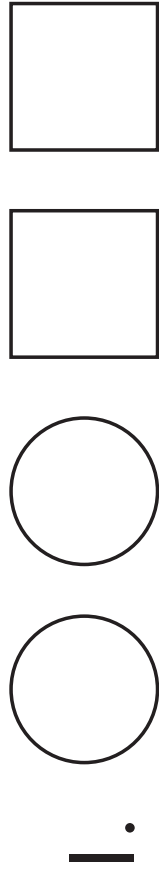

Name: _____

Shape Patterns: AABB

Draw shapes to complete each pattern.

1.

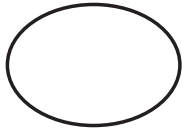
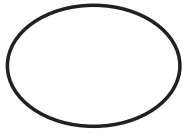

2.

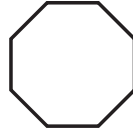
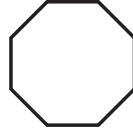

3.

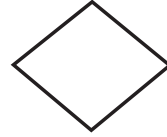
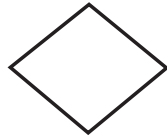

Name: _____

Draw shapes to complete each pattern.

1.

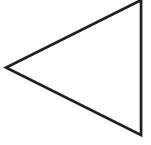
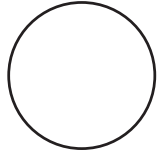
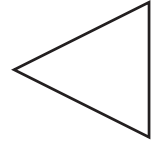

2.

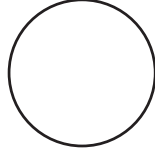
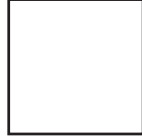
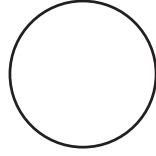
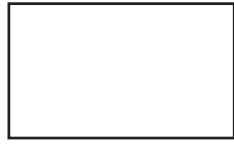

3.

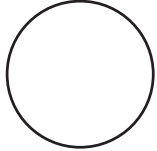
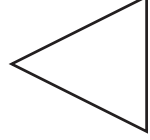
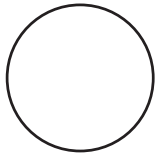
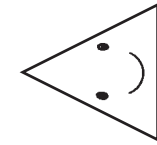

Name: _____

Draw shapes to complete each pattern.

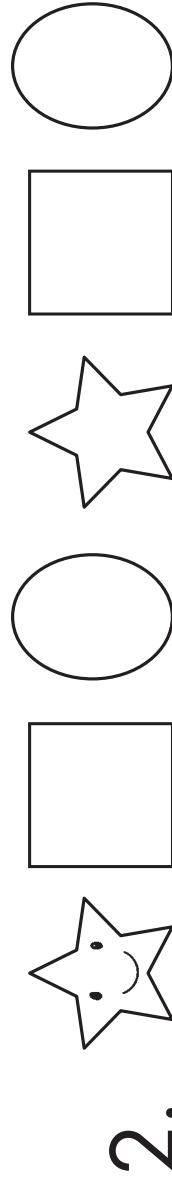
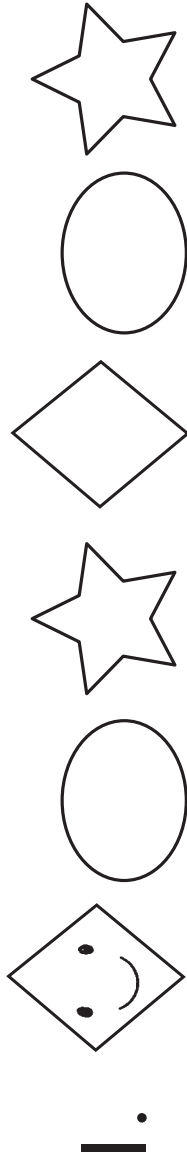

Name: _____

Color each shape.
Draw an x on the
blue \triangle .

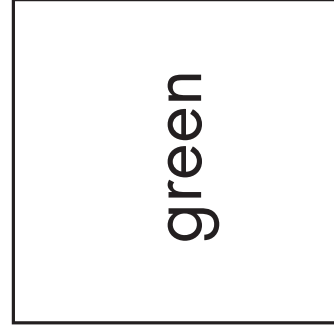
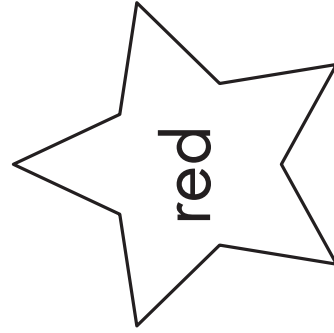
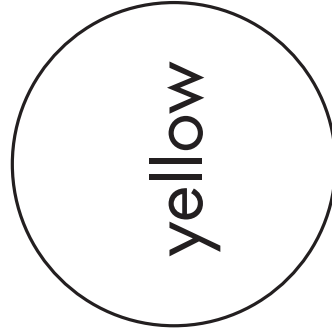
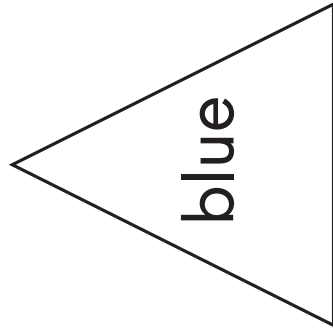

Color each shape.
Draw an x on the
red \circ .

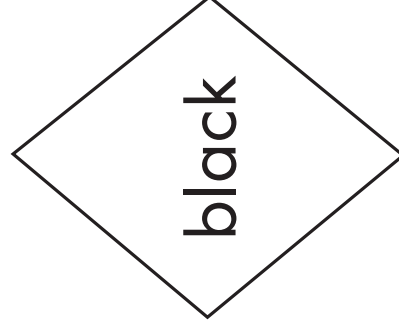
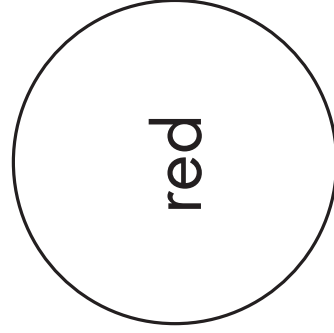
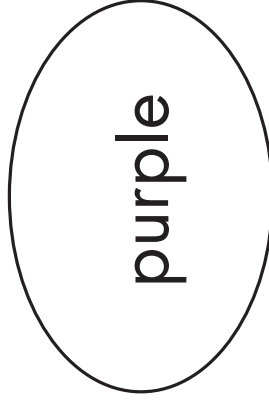
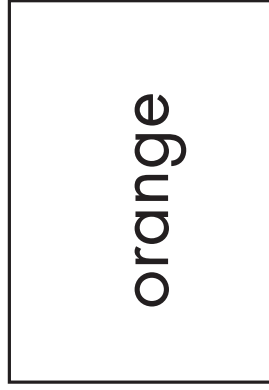
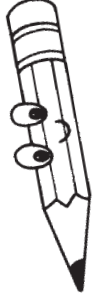

Name: _____

Color each shape.
Draw an x on the **orange** □.

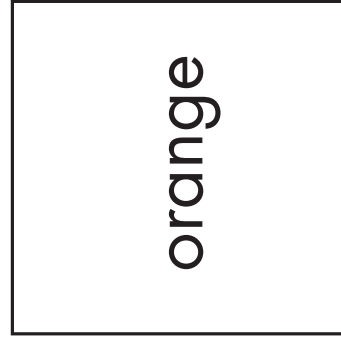
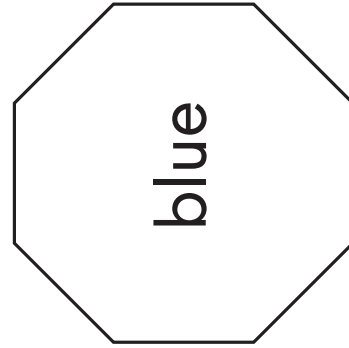
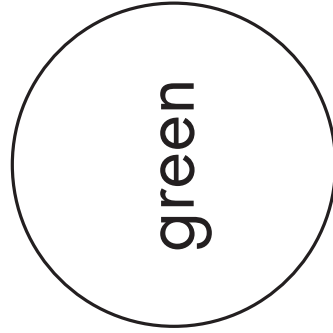
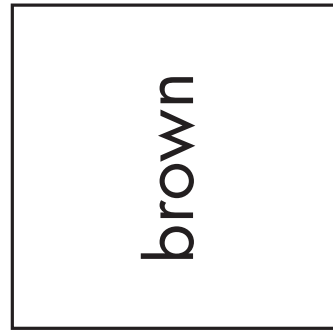

Color each shape.
Draw an x on the **green** ☆.

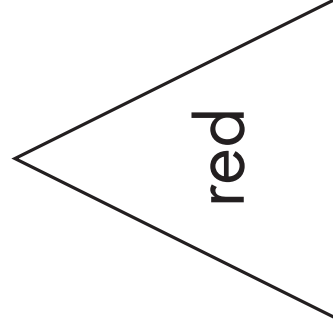
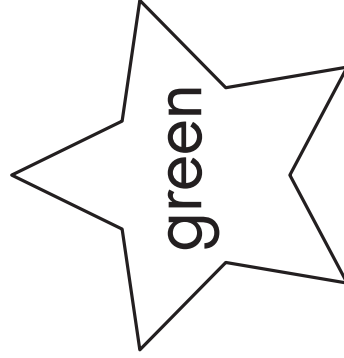
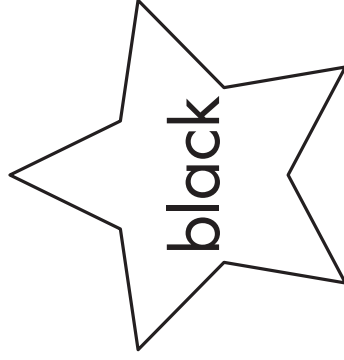
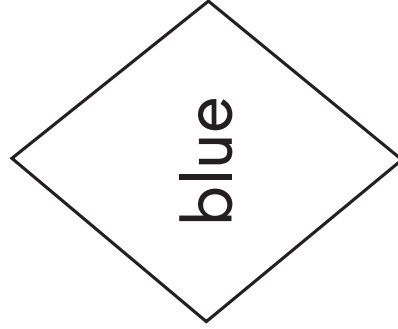

Name: _____

Color each shape.
 Draw an x on the
small blue △.

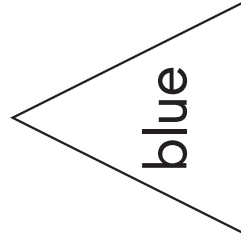
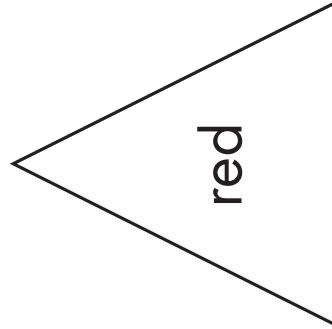
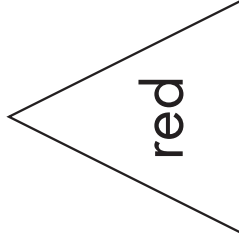
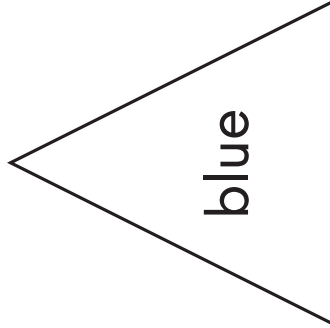

Color each shape.
 Draw an x on the
big red ○.

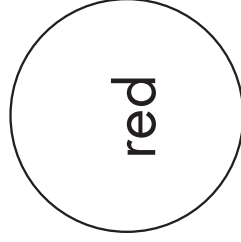
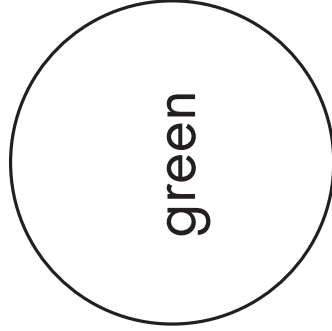
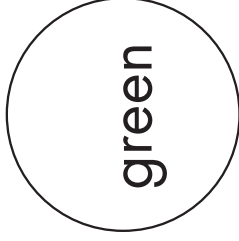
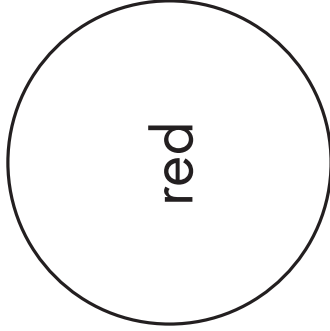

Name: _____

Attributes: Color & Size

Color each shape.
Draw an x on the **big orange** □.

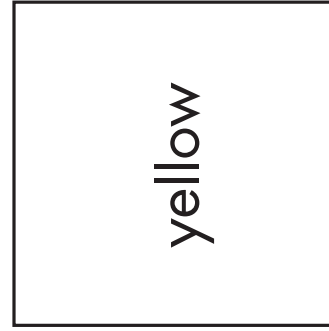
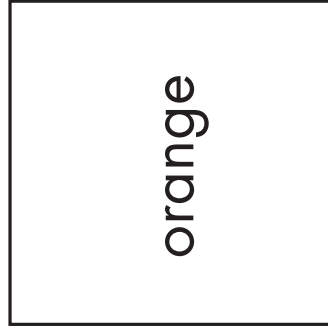

Color each shape.
Draw an x on the **small blue** ☆.

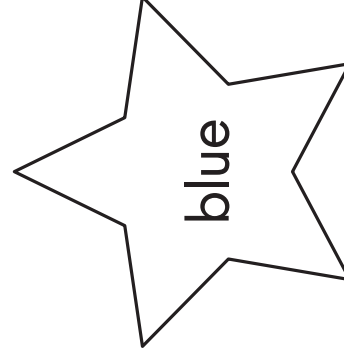
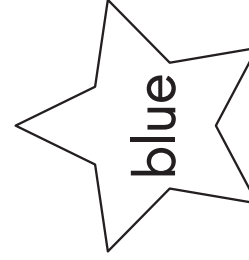
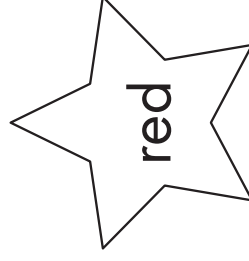
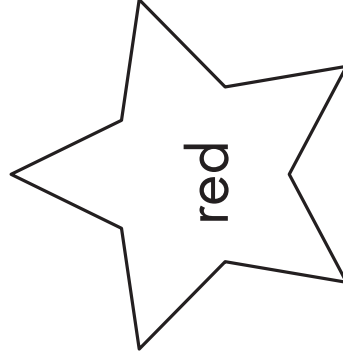
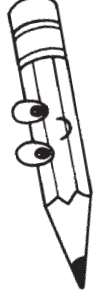

Name: _____

Color each shape brown.

Draw an x on the

small ◇.

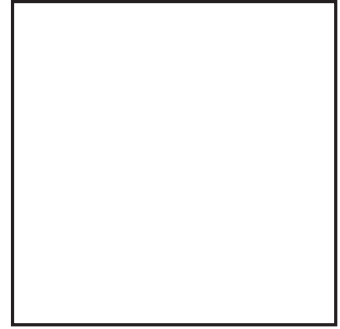
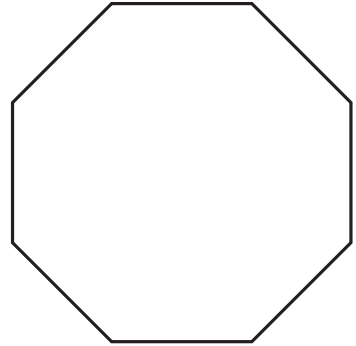
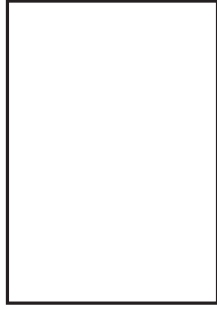
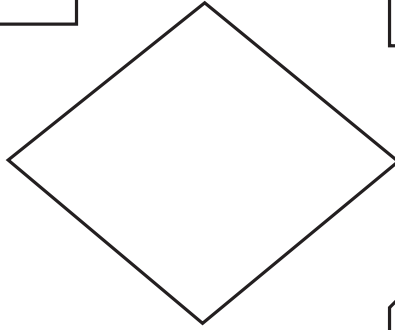
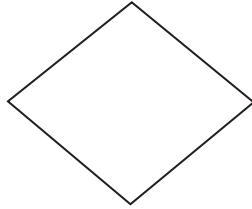

Color each shape red.

Draw an x on the

big ☆.

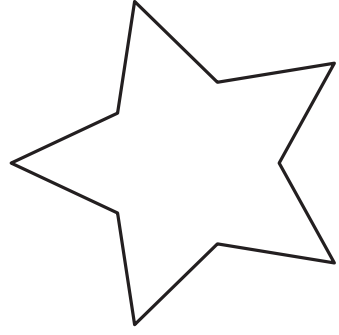
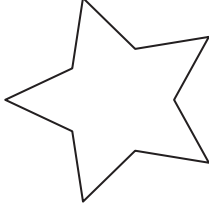
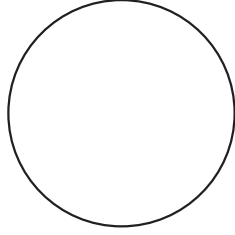
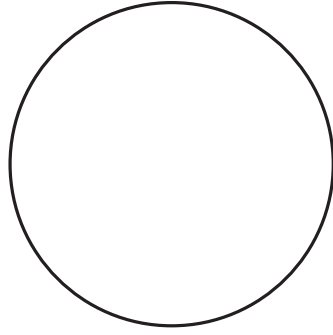
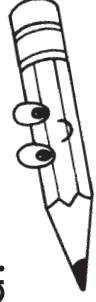

Name: _____

Attributes: Shape & Size

Color each shape green.

Draw an x on the

big .

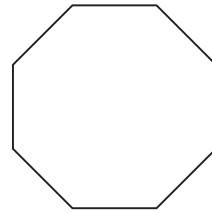
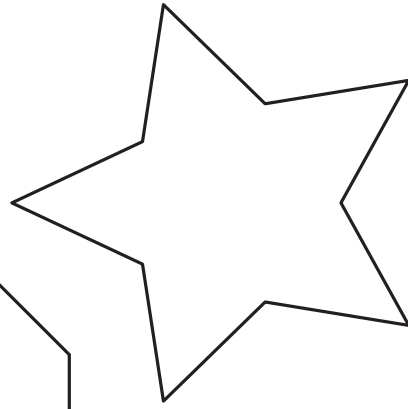
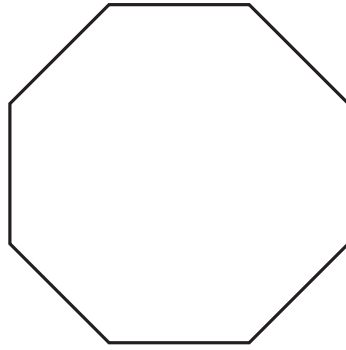
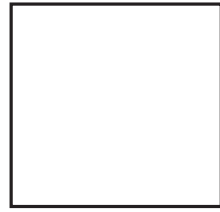
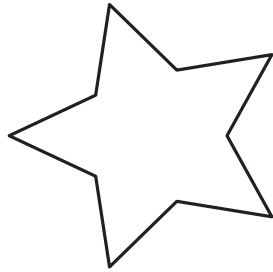
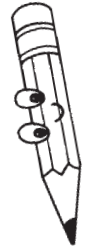

Color each shape purple.

Draw an x on the

small .

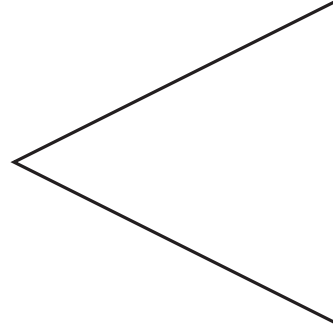
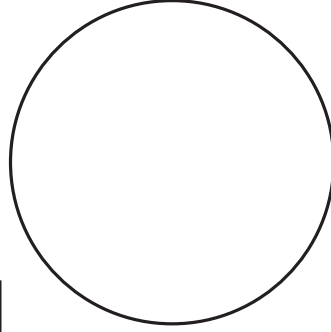
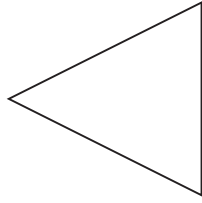
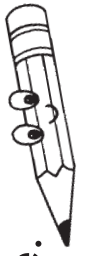

Name: _____

Draw pictures to complete each pattern.

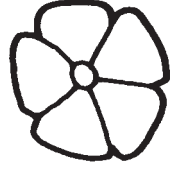
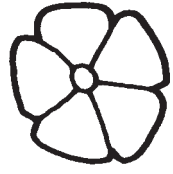
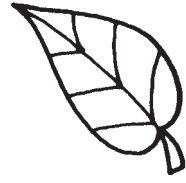

1.

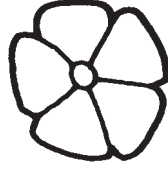
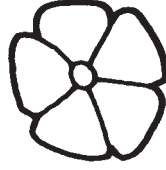
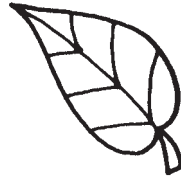
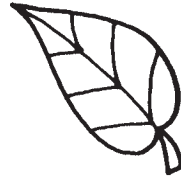

2.

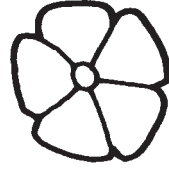
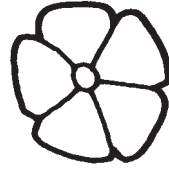
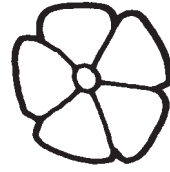

3.

Name: _____

Draw pictures to complete each pattern.

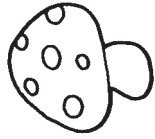
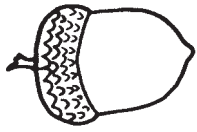
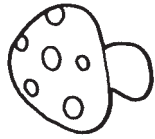
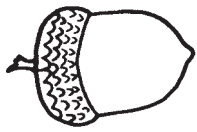

1.

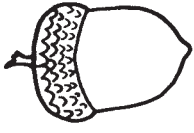
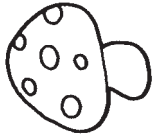
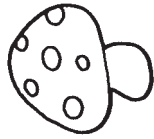
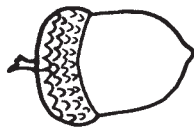

2.

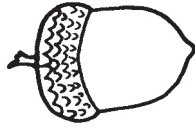
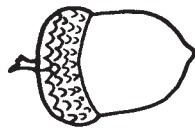
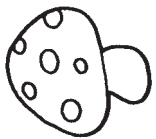
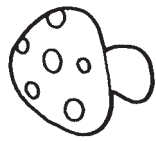

3.

Name: _____

Draw pictures to complete each pattern.

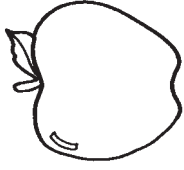
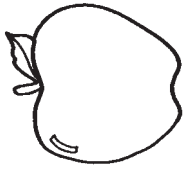
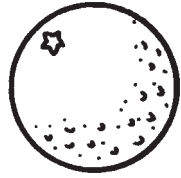
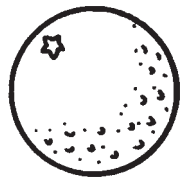

1.

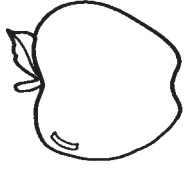
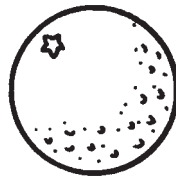
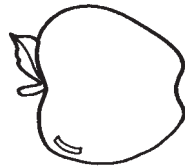
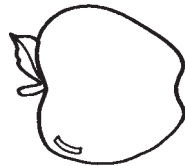

2.

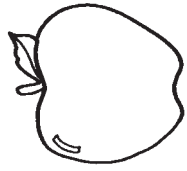
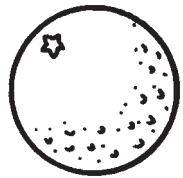
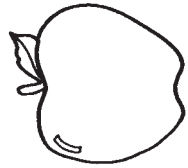
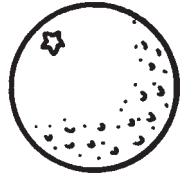

3.

Name: _____

Draw pictures to complete each pattern.

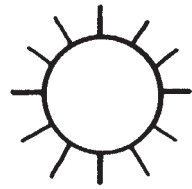

1.

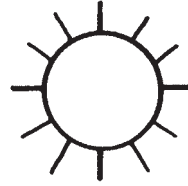

2.

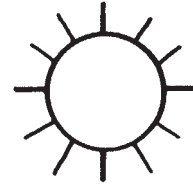
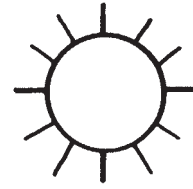

3.

Write letters to complete each pattern.

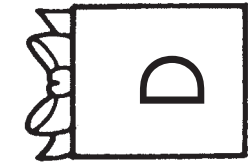

1.

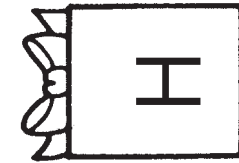
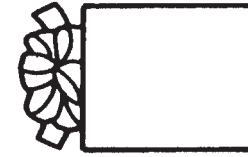
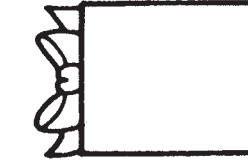
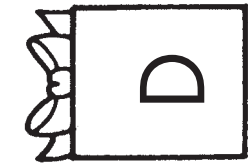

2.

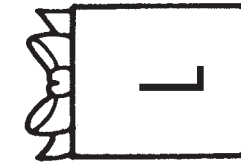
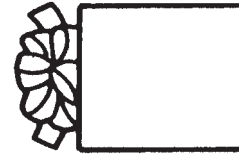
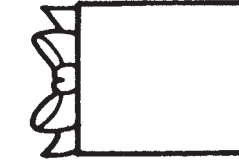
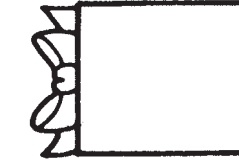
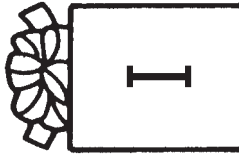
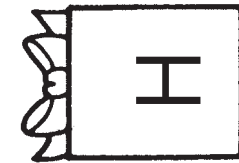
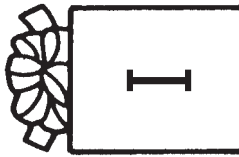

3.

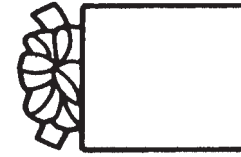
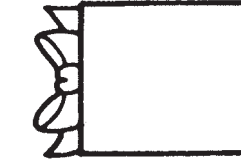
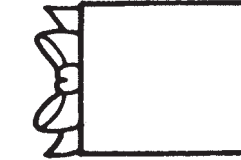
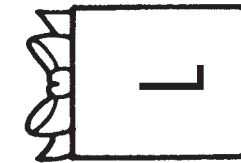

Name: _____

Write letters to complete each pattern.

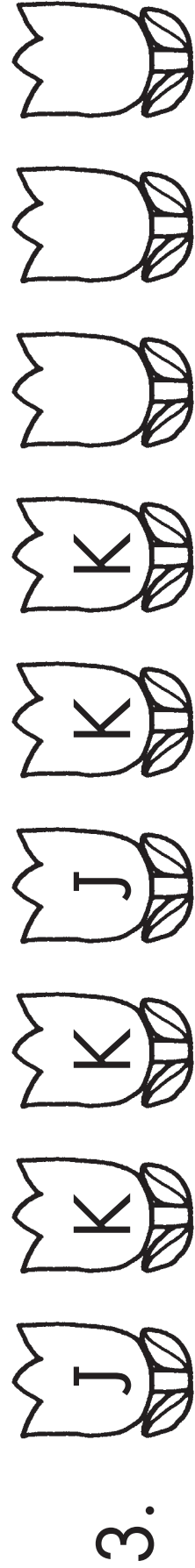
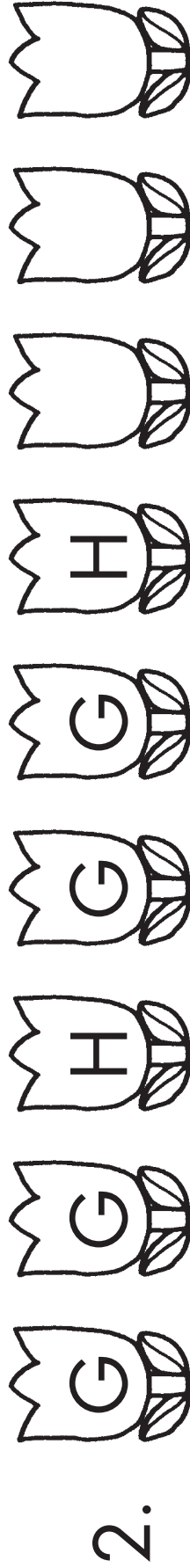





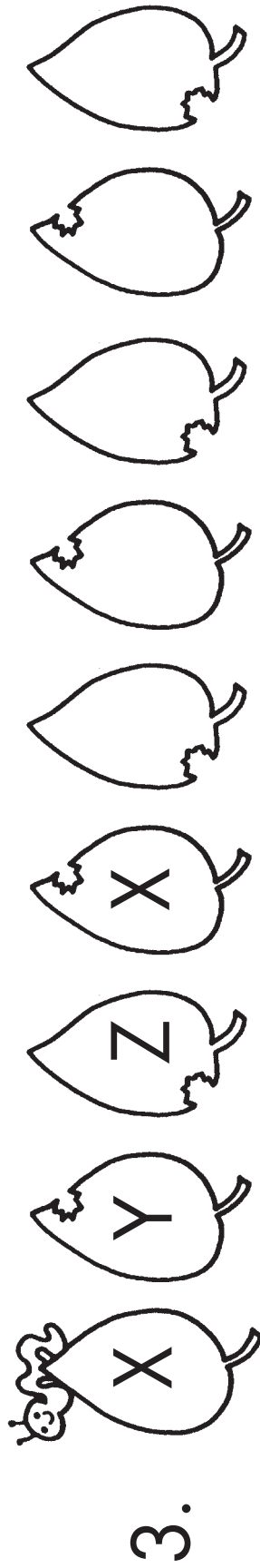
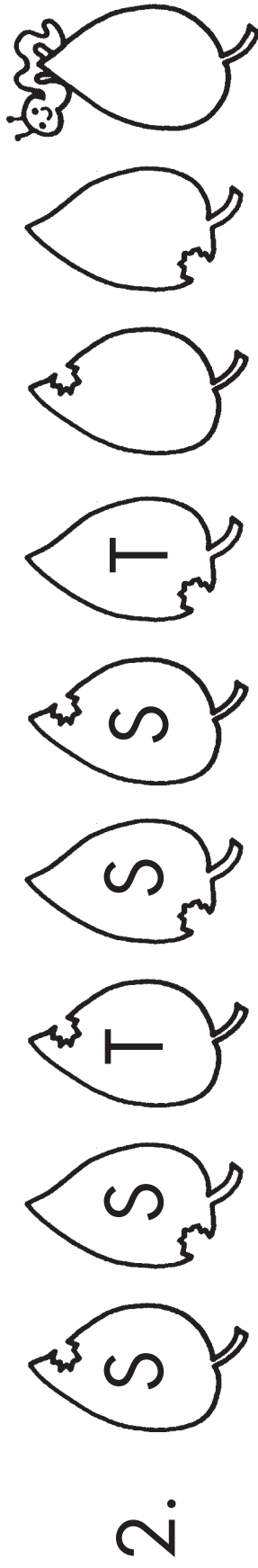
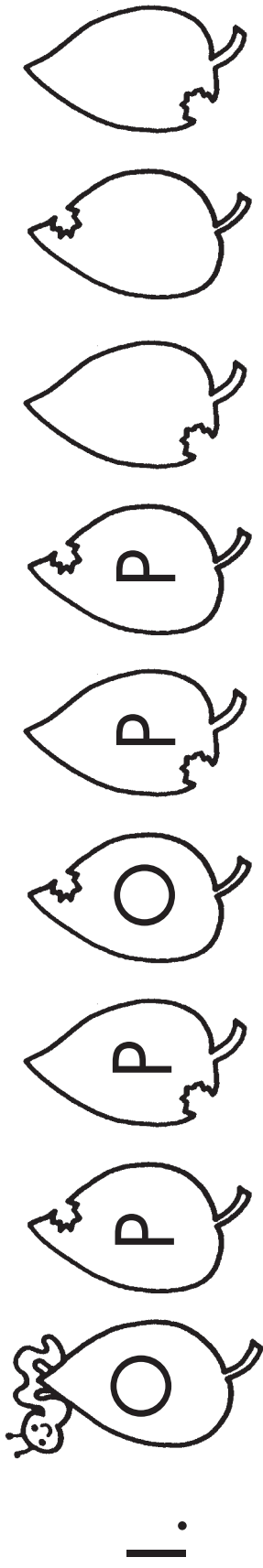



Name: _____

Write letters to complete each pattern.











Write letters to complete each pattern.













1.

	Q		Q		R		Q		Q		R			
---	---	---	---	---	---	---	---	--	---	---	---	---	---	---

2.

	U		V		W		U		V		W			
---	---	---	---	---	---	---	---	--	---	---	---	---	---	---

3.

	N		O		P									
---	---	---	---	---	---	---	--	---	---	---	---	---	---	---

Write letters to complete each pattern.

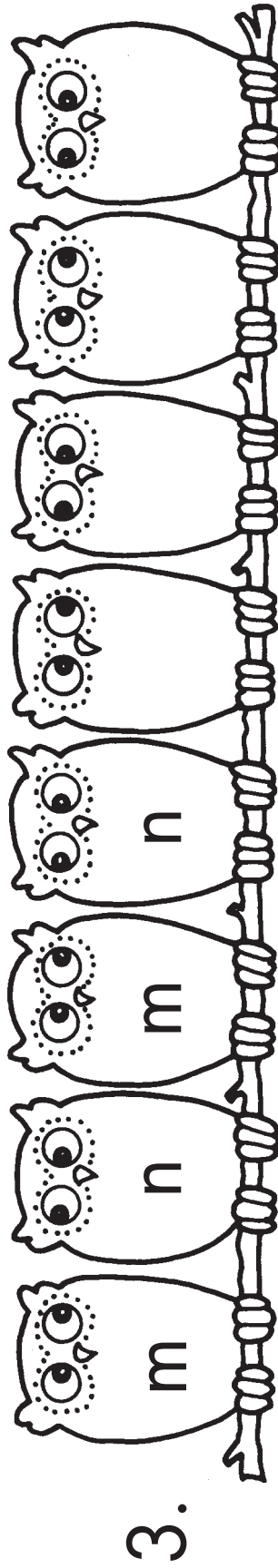
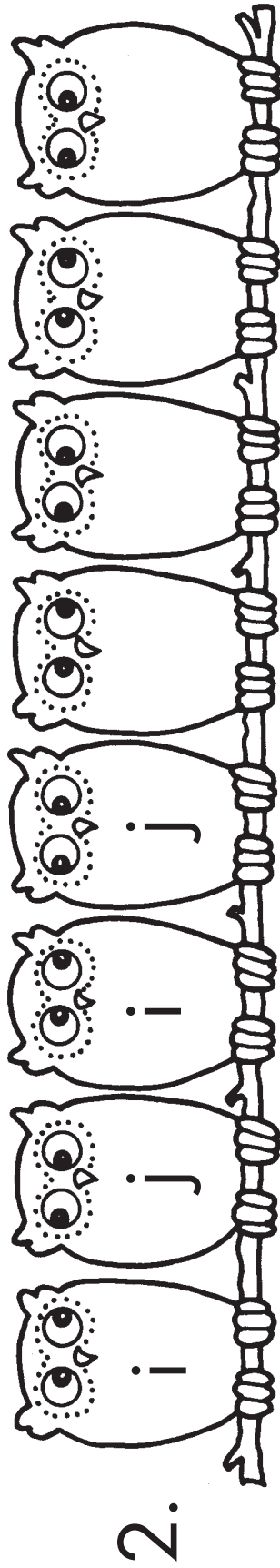
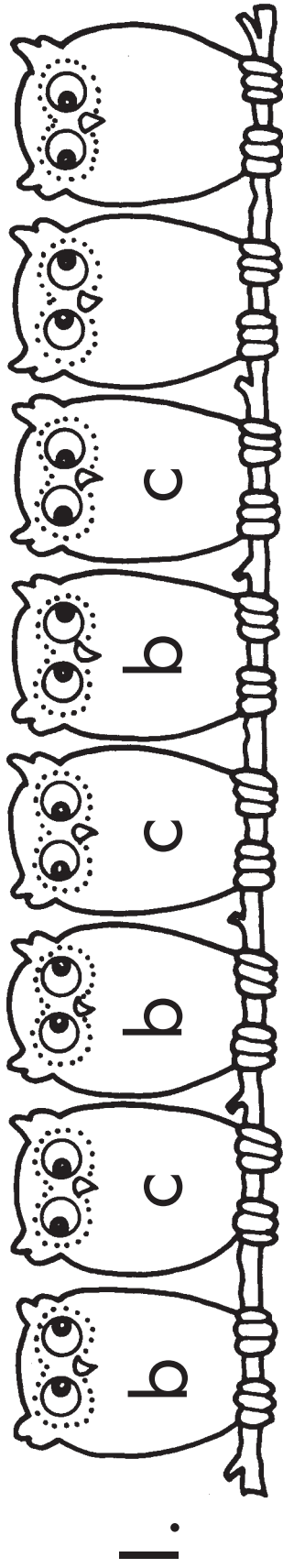

Name: _____

Write letters to complete each pattern.

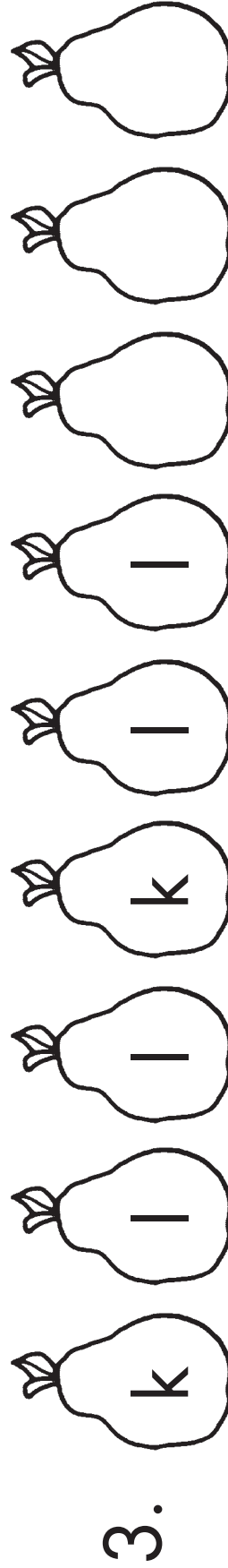
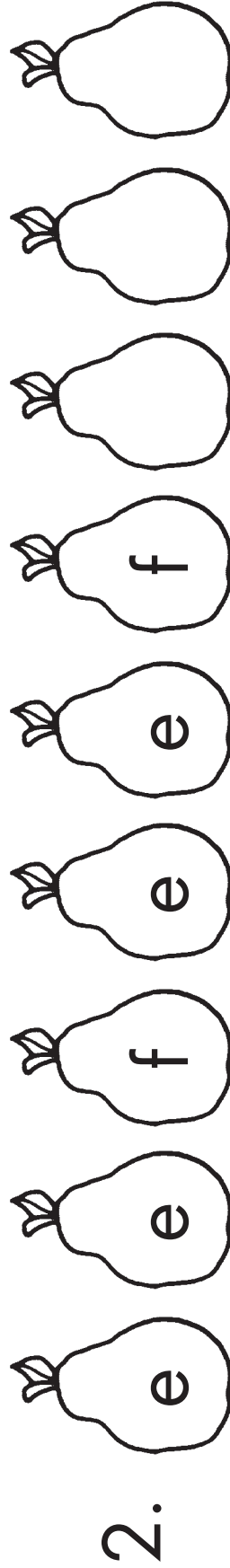
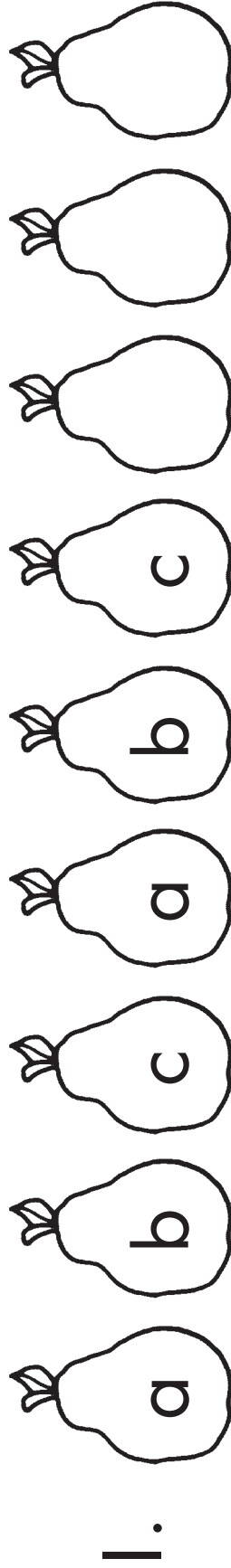

Name: _____

Write letters to complete each pattern.

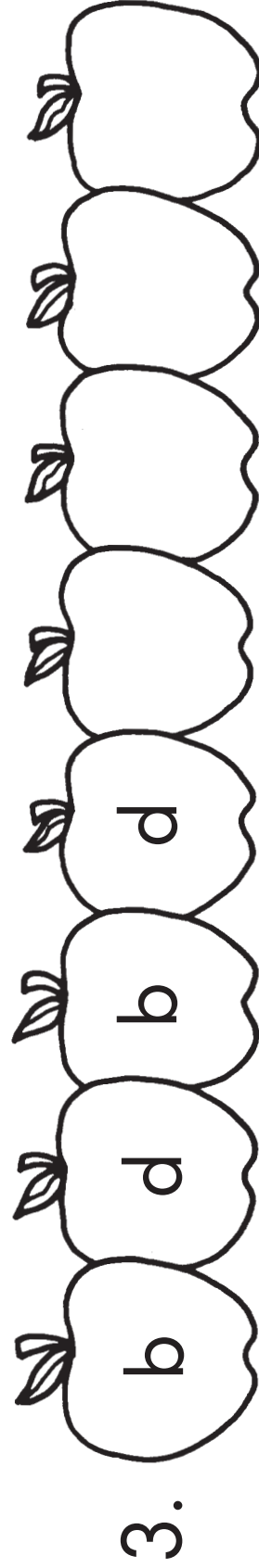
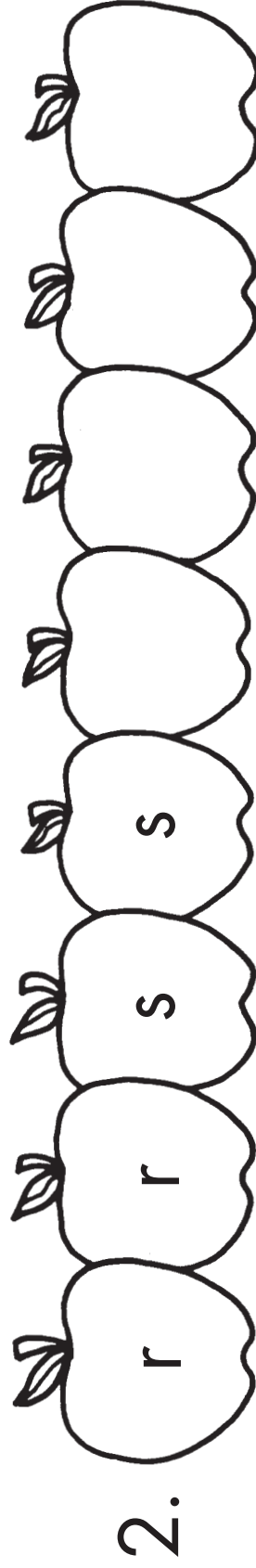
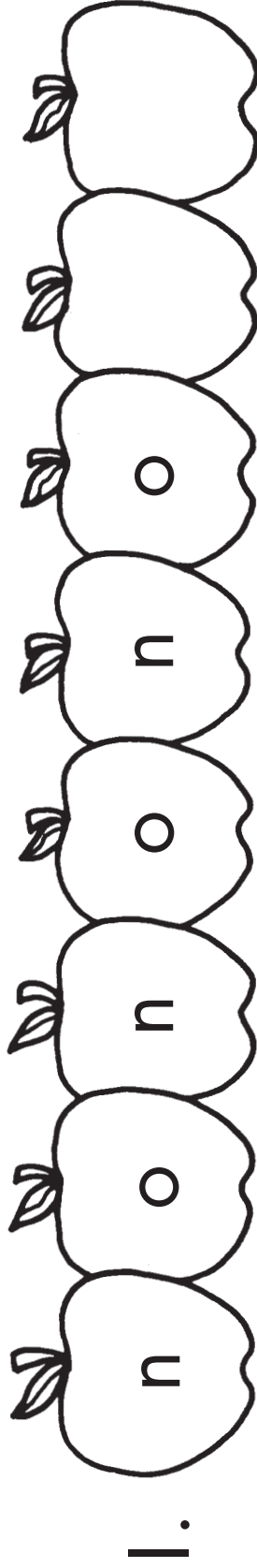

Write letters to complete each pattern.

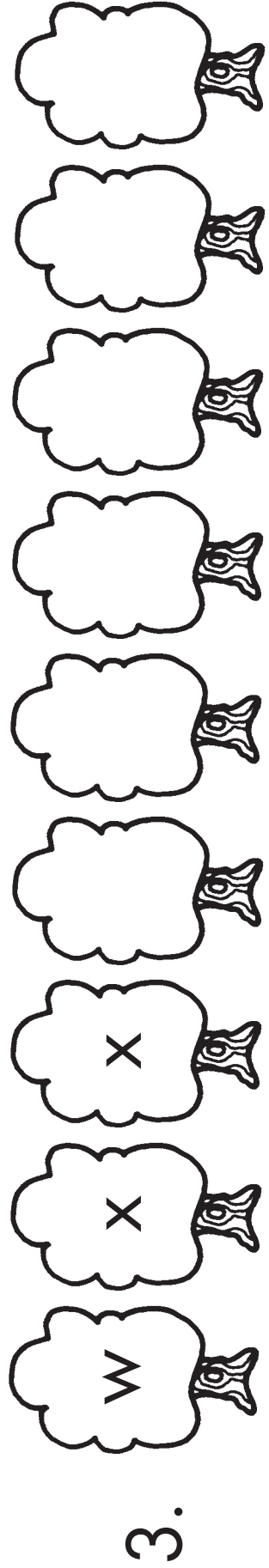
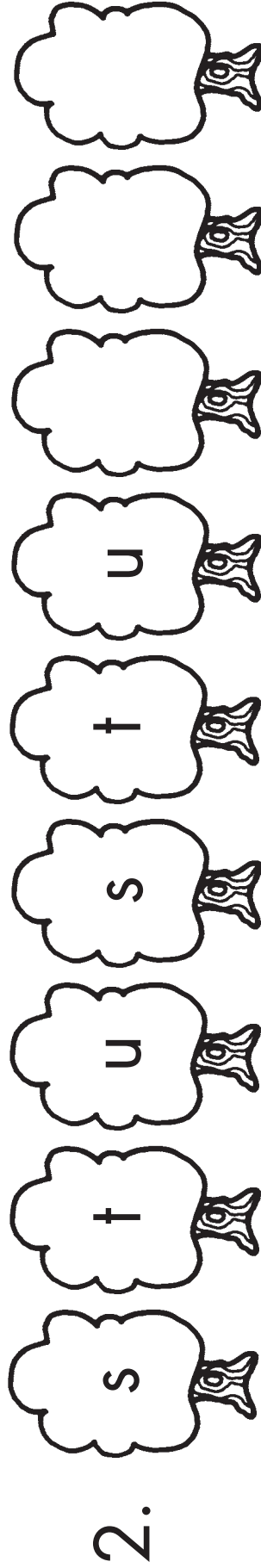
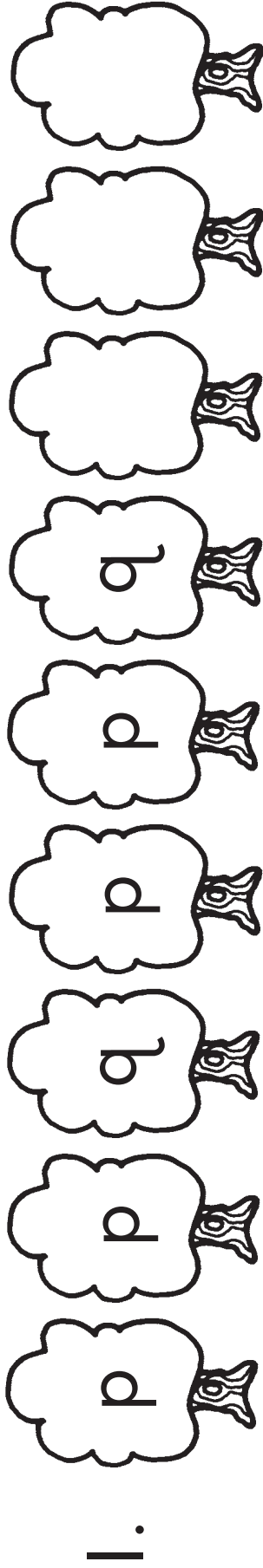

Name: _____

Write letters to complete each pattern.

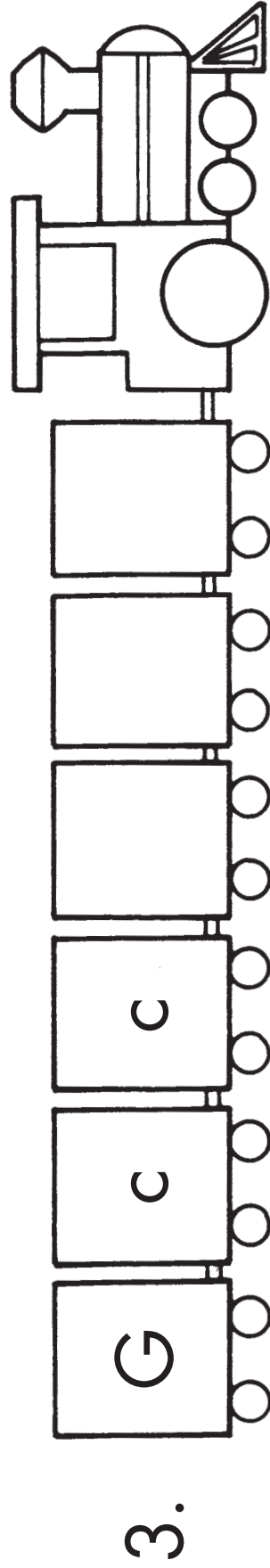
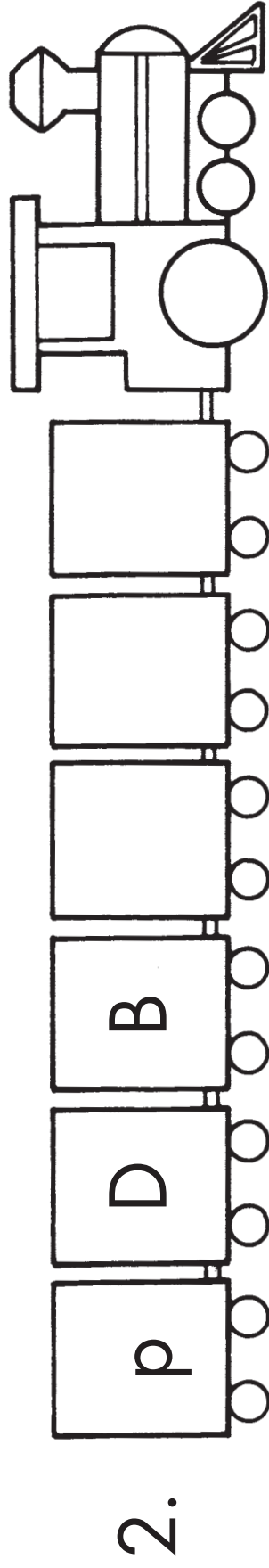
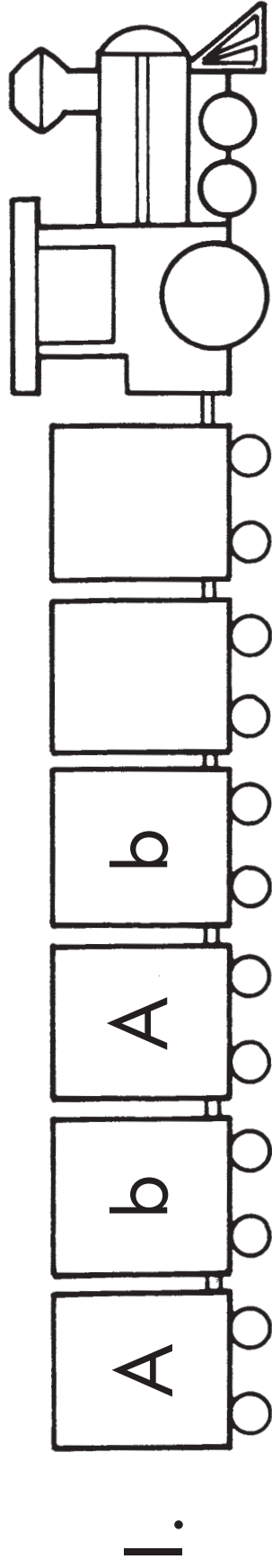

Name: _____

Write letters to complete each pattern.

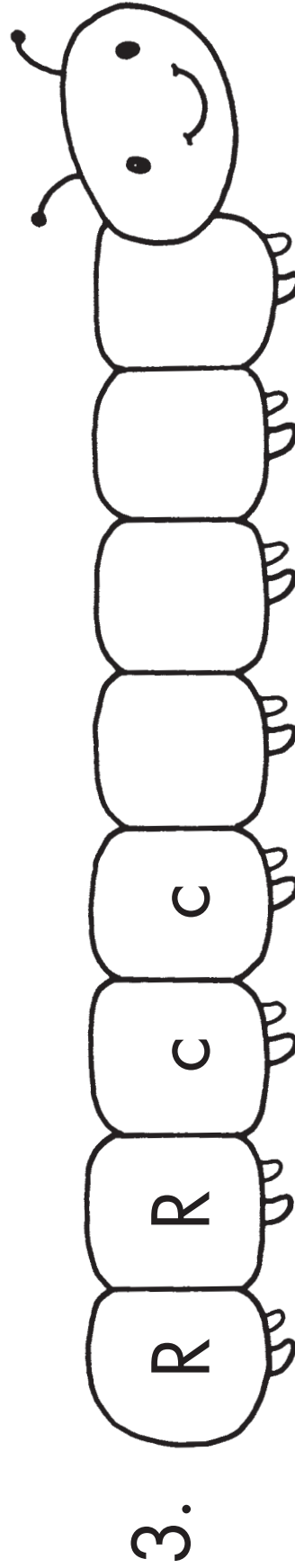
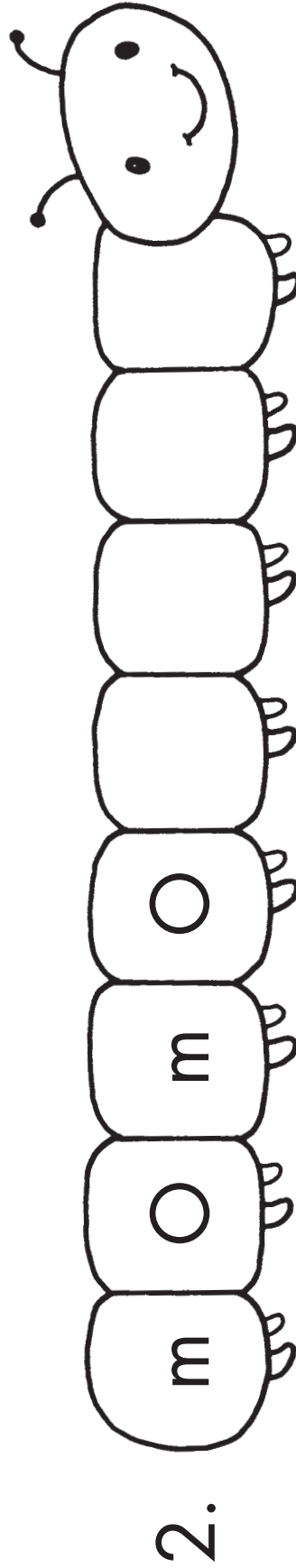
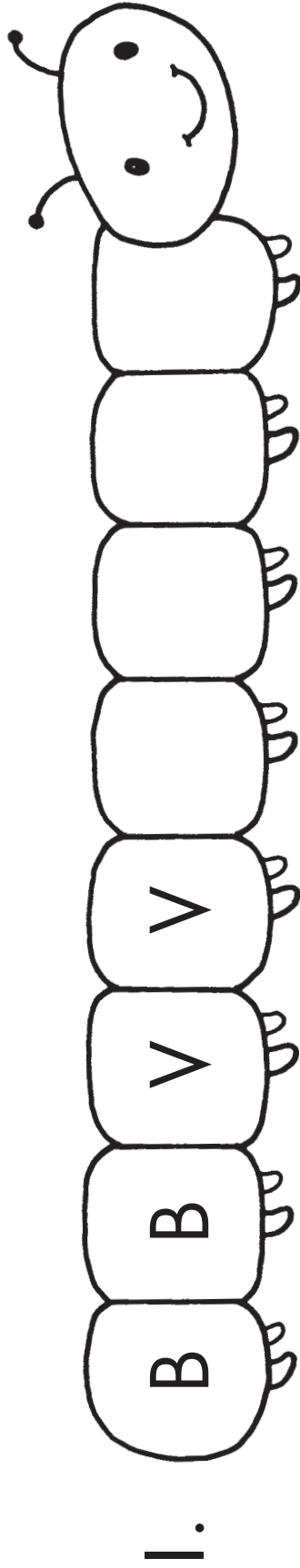

Name: _____

Write numbers to complete each pattern.

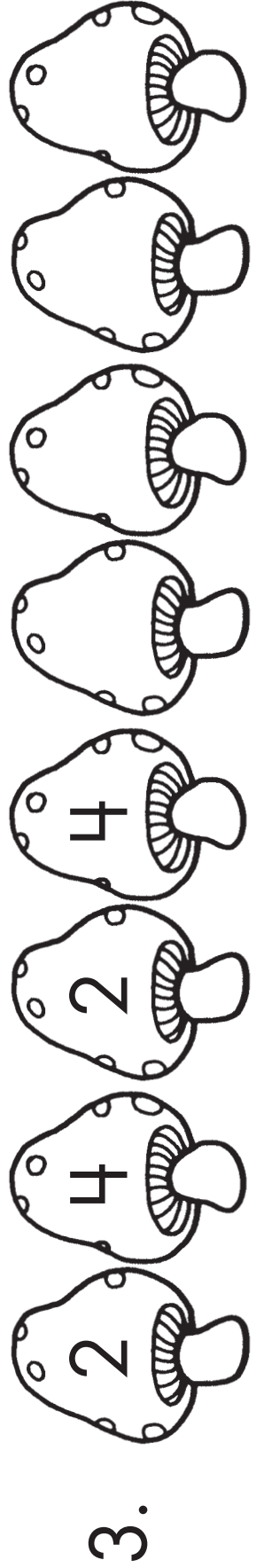
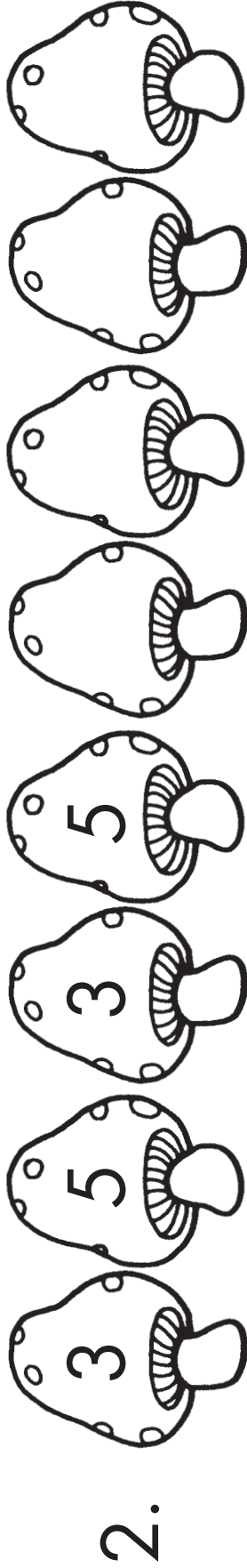
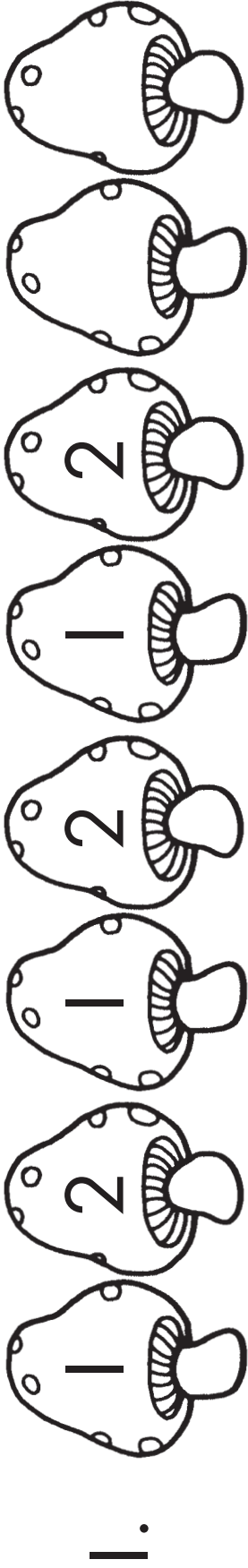





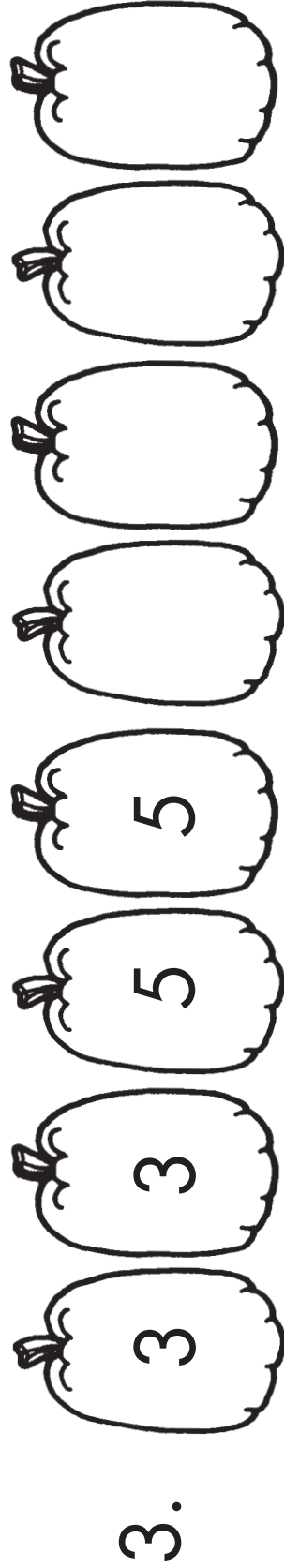
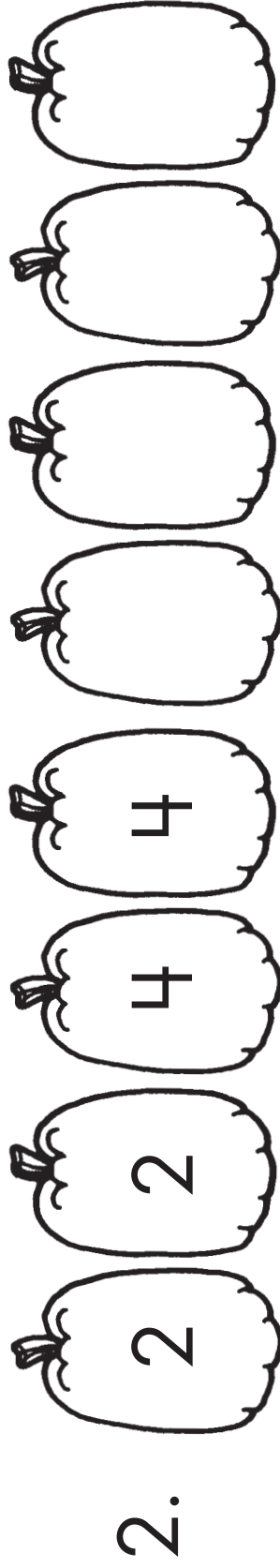

Name: _____

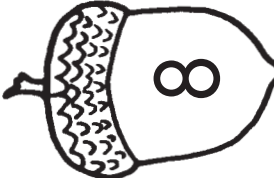
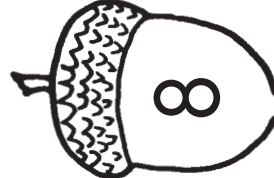
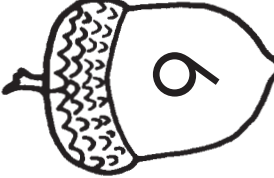
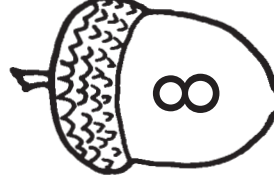
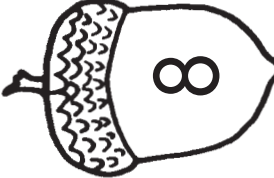
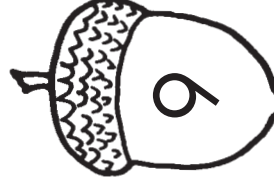
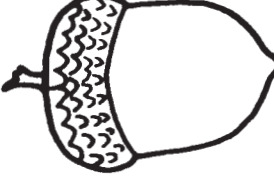
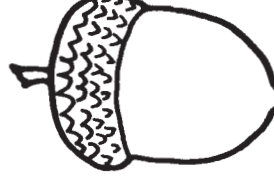

Write numbers to complete each pattern.

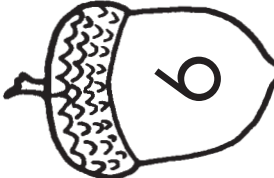
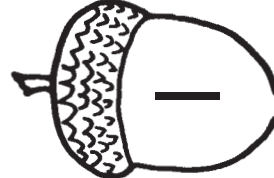
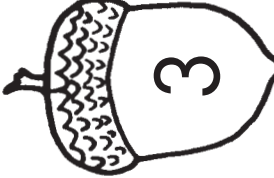
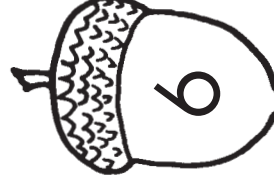
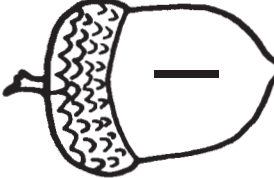

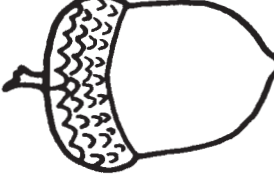
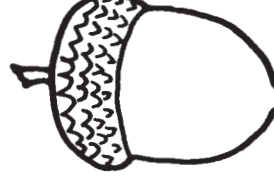
Write numbers to complete each pattern.

1.         

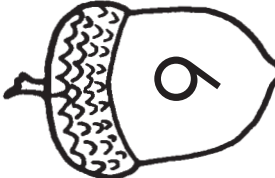
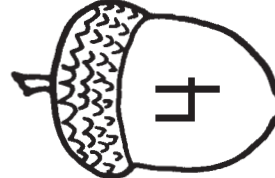
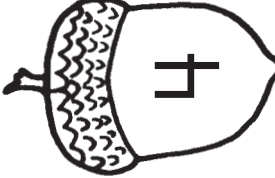
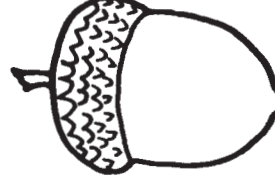
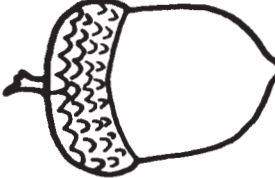
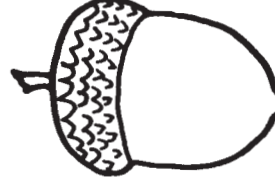
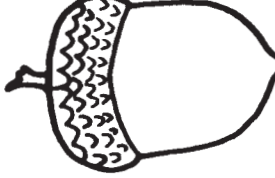
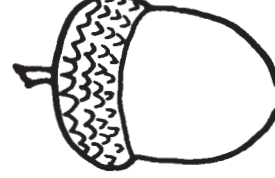
2.         

3.         

Name: _____

Write numbers to complete each pattern.

1.

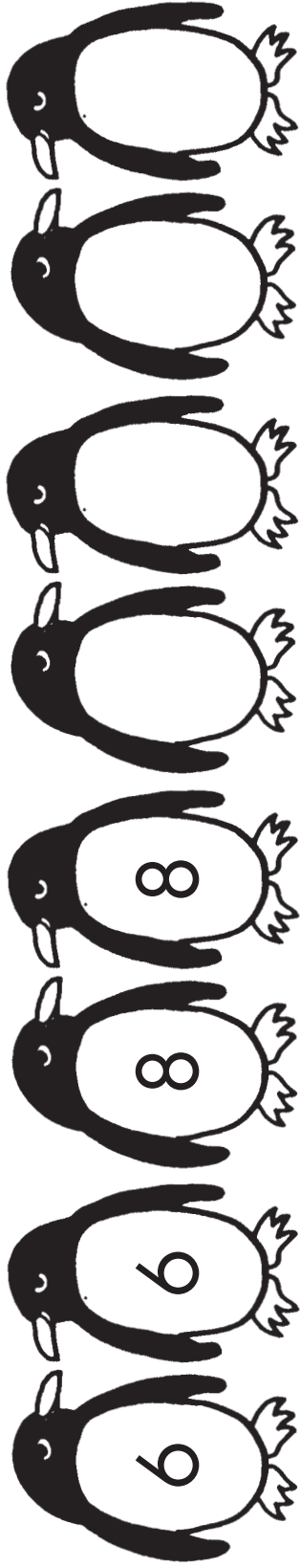

2.

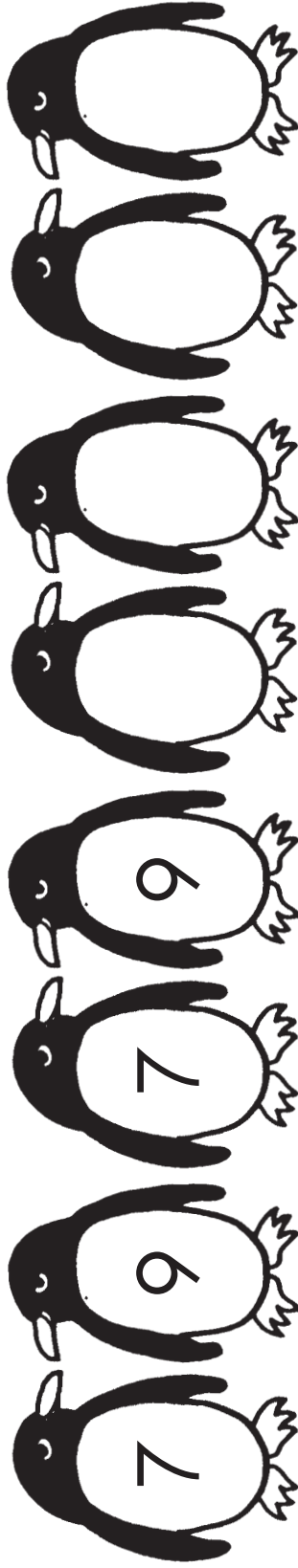

3.

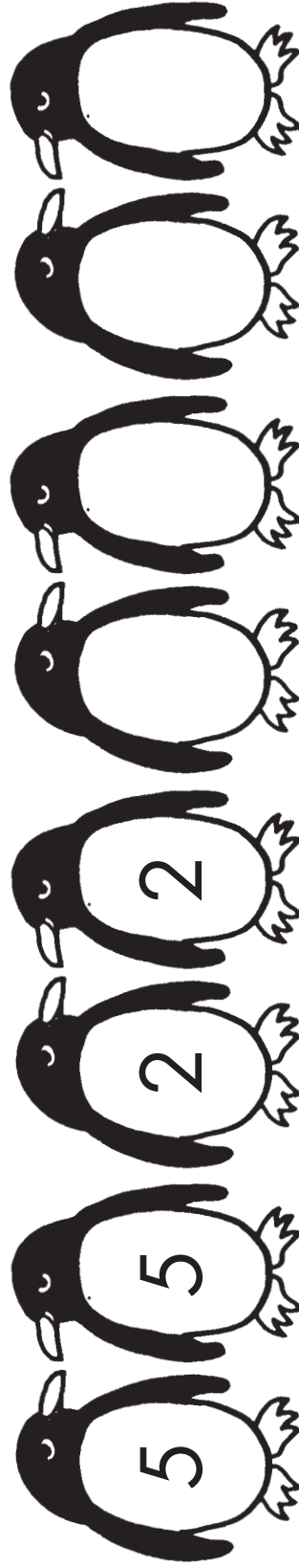

Name: _____

Complete each pattern.

1.

2.

3.

Name: _____

Complete each pattern.

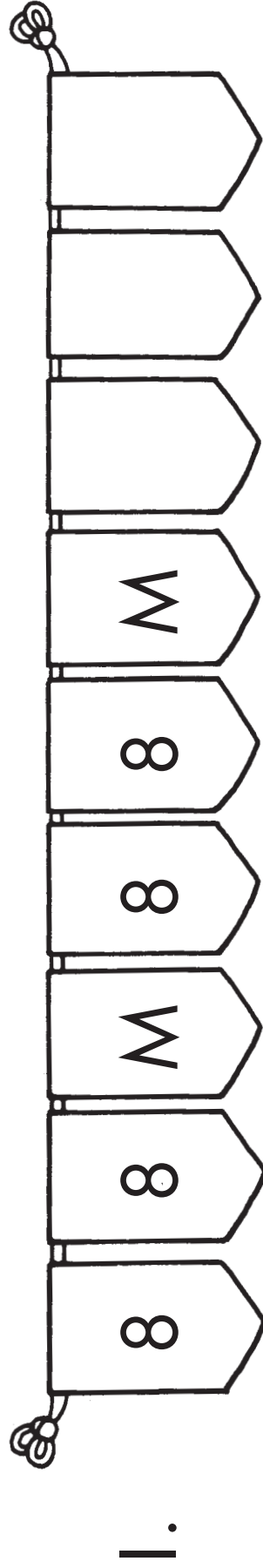
1. 

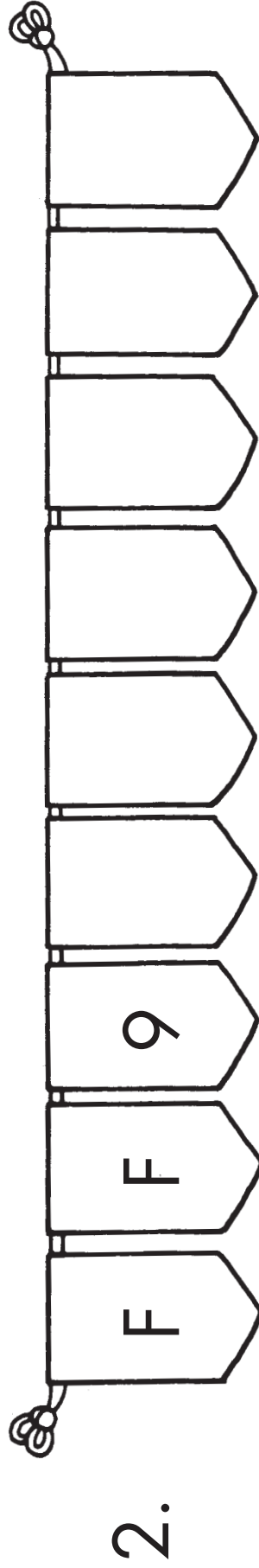
2. 

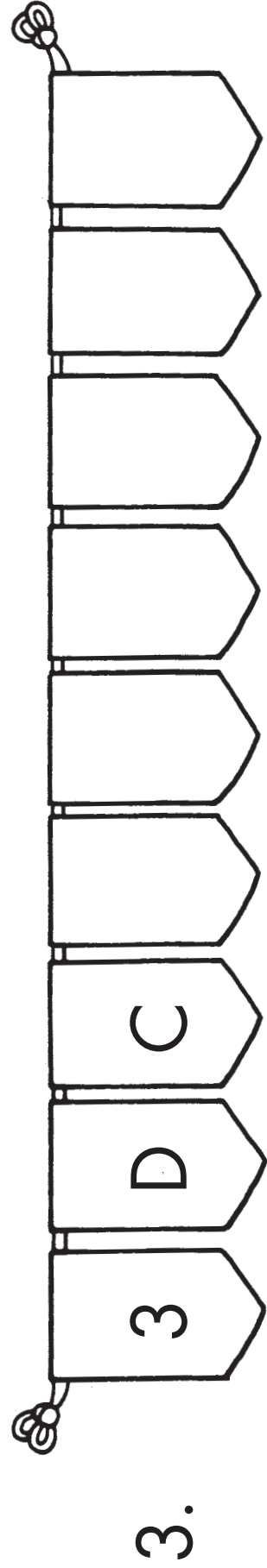
3. 

Name: _____

What comes next in each pattern? Circle your answer.

1.

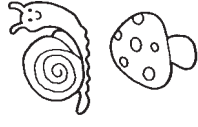

2.

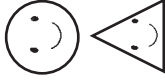



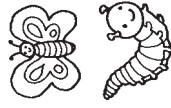





3.













Draw your own pattern! Use two pictures.

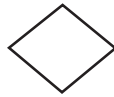

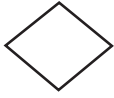
Name: _____

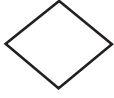

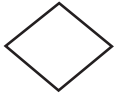

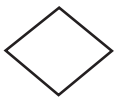



What comes next in each pattern? Circle your answer.



1.         _____

2.          _____

3.          _____

Draw your own pattern! Use three shapes.

Name: _____

Identifying Patterns

Finish labeling each pattern.



1. A B A B A B _____



2. A B A B _____

Draw your own **AB** pattern. Use pictures.

_____ B _____ A _____ B _____ A _____ B

Name: _____

Identifying Patterns

Finish labeling each pattern.



1. A B A B _____



2. A B _____

Draw your own **AB** pattern. Label the pattern.

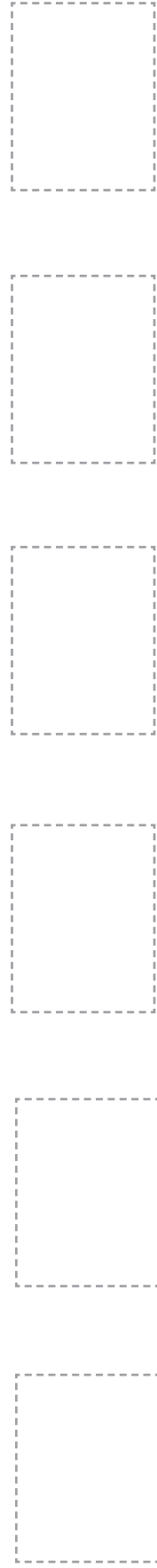

Name: _____

Identifying Patterns

Finish labeling each pattern.



1. A A B A A B _____

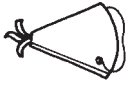
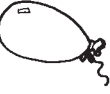
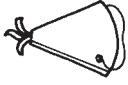
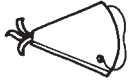
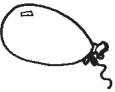
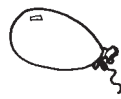

2. A A B _____

Draw your own **AAB** pattern. Use pictures.

_____ A _____ B _____ A _____ B

Name: _____

Identifying Patterns

Finish labeling each pattern.

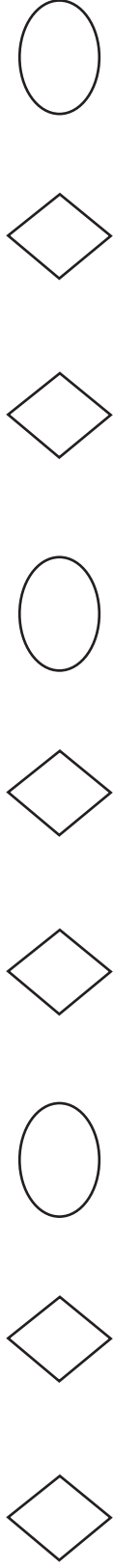

1. A A B A _____



2. A A B _____

Draw your own **AAB** pattern. Label the pattern.



Name: _____

Identifying Patterns

Finish labeling each pattern.



1. A B A B A B _____



2. A B B _____

Draw your own **ABB** pattern. Use pictures.

_____ A _____ B _____ A _____ B _____

Name: _____

Finish labeling each pattern.



1. A B B A _____

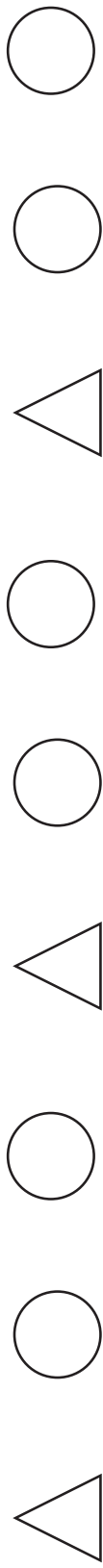

2. A B B _____

Draw your own **ABB** pattern. Label the pattern.



Name: _____

Identifying Patterns

Finish labeling each pattern.

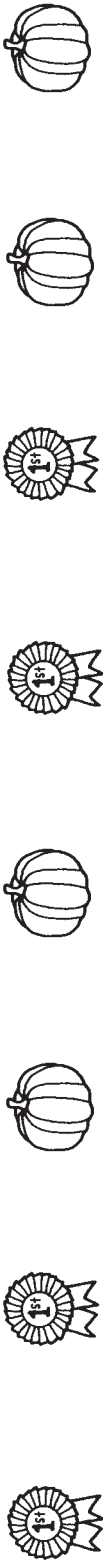

1. A A B B A A _____



2. A A B B _____

Draw your own **AABB** pattern. Use pictures.

_____ A A B B _____ A A B B _____

Name: _____

Identifying Patterns

Finish labeling each pattern.



1. A A B _____

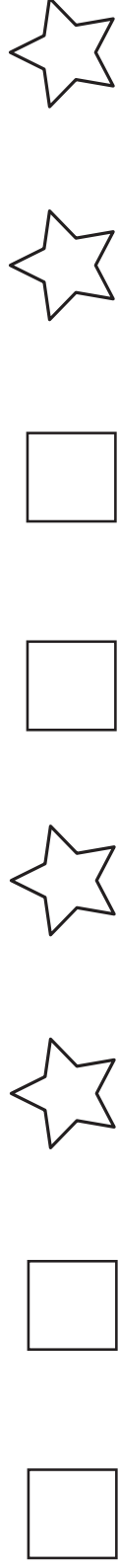

2. A A _____



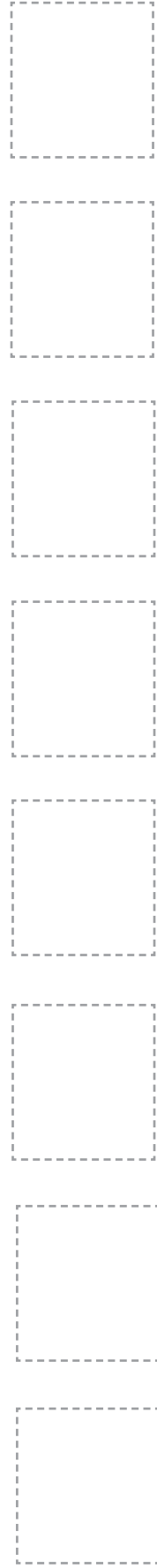





Draw your own **AABB** pattern. Label the pattern.



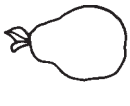

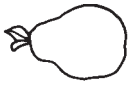





Name: _____

Identifying Patterns

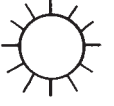
Finish labeling each pattern.

1.          _____

A B C A B C _____

2.          _____

A B C _____

Draw your own **ABC** pattern. Use pictures.

_____ B _____ A _____ C _____

Name: _____

Identifying Patterns

Finish labeling each pattern.

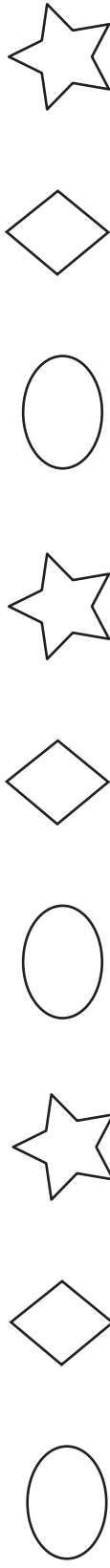

1. A B C A _____

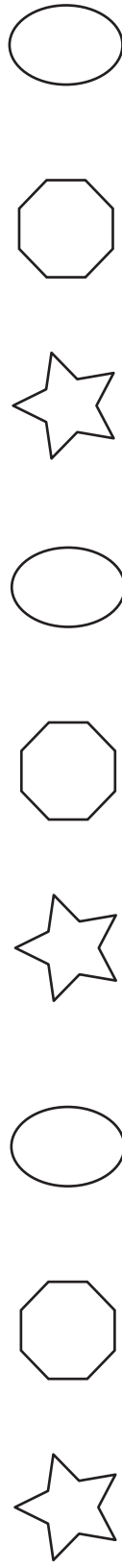

2. A B C _____

Draw your own **ABC** pattern. Label the pattern.

